

Installation Instructions

underground distribution system with horizontal
swivelling equipment compartment
EK880 | EK890



1	<u>General information</u>	4
2	<u>Safety information</u>	4
	2.1 <u>Electrical installation kit</u>	4
	2.2 <u>General</u>	5
3	<u>Illustration of the “snorkel effect” principle</u>	6
4	<u>Product description</u>	7
	4.1 <u>Technical data</u>	7
	4.2 <u>Package includes</u>	8
	4.3 <u>Required tools</u>	8
	4.3.1 <u>Included</u>	8
	4.3.2 <u>Not included</u>	8
5	<u>Foundation pit base</u>	9
	5.1 <u>General</u>	9
	5.2 <u>Preparing the foundation pit base</u>	9
	5.2.1 <u>Drainage</u>	9
	5.2.2 <u>Possible situations for the foundation pit base</u>	10
6	<u>Installation</u>	11
	6.1 <u>Preparing the underfloor distribution system</u>	11
	6.2 <u>Inserting the underground distribution system</u>	11
	6.3 <u>Opening the triangular cover</u>	11
	6.4 <u>Grounding</u>	12
	6.5 <u>Closing the triangular covers</u>	12
	6.6 <u>Fitting the protective pipe seals</u>	13
7	<u>Constructing the surrounding surface</u>	13
	7.1 <u>Backfilling the foundation pit up to the lower edge of the top layer</u>	13
	7.2 <u>Removing the triangular covers</u>	14
	7.3 <u>Lifting the cast-iron frame</u>	14
	7.4 <u>Fitting the height adjustment hole plug</u>	14
	7.5 <u>Adjusting the height</u>	15
	7.6 <u>Filling the height-adjustment gap</u>	16
	7.7 <u>Inserting the triangular covers</u>	17
	7.8 <u>Constructing the top layer</u>	17
8	<u>Operation</u>	18
	8.1 <u>Swivelling out the cover</u>	18
	8.2 <u>Opening the cover</u>	19
	8.3 <u>Swivelling in the cover</u>	19

<u>9</u>	<u>Maintenance</u>	<u>20</u>	
	<u>9.1</u>	<u>General measures</u>	<u>20</u>
<u>10</u>	<u>Accessories</u>	<u>20</u>	
<u>11</u>	<u>Declaration of Conformity</u>	<u>21</u>	
<u>12</u>	<u>Material defects</u>	<u>22</u>	
<u>13</u>	<u>Quality management</u>	<u>22</u>	
<u>14</u>	<u>Disclaimer/Warranty</u>	<u>22</u>	
<u>15</u>	<u>Contact</u>	<u>22</u>	

1 General information



Note!

Any person involved in the assembly, connection, operation, maintenance, and repair of the product must first read, understand and follow these instructions. We accept no liability for damage and operational malfunctions caused by failure to comply with these instructions.

In the interest of further development, we reserve the right to change individual assemblies and accessories as considered necessary for enhanced safety and performance improvements, while preserving the main features.

The copyright of these instructions remains with Langmatz GmbH.

2 Safety information

The product complies with the latest state-of-the-art technology at the time of printing and is delivered in an operationally safe condition. Unauthorised modifications, particularly to safety-related parts, are prohibited.

Langmatz GmbH warns against the misuse of the product.

Before opening, ensure that the underground distribution system is not flooded.

2.1 Electrical installation kit

All electrical components must meet the applicable standards when installing them.

Protect electrical components from the harmful effects of water. Langmatz recommends the use of Langmatz diving-bell cabinets.

2.2 General

- Information signs attached to the underground distribution system must be observed.
- Information signs must be kept clean. Missing or illegible signs must be replaced.
- Regular maintenance and cleaning are essential for safe operation and must be performed by trained professionals (see also section 9).

Note when folding down!



- Do not allow cables to be crushed!
- Keep folding and swivelling areas clear when folding down! **Risk of injury! Crushing of limbs.**
- Clear folding and swivelling areas of dirt and other objects.

The operating company is responsible for installing, operating and maintaining the fixtures.

The operating company is responsible for the following:

- Preventing danger to the life and limb of users and third parties.
- Ensuring operational safety.
- Preventing downtime and environmental impact due to incorrect handling.
- Ensuring that protective clothing is worn when working with or on the product.
- Ensuring that users receive instructions in the proper operation of the underground distribution system.

Do not use the product if the mechanics are damaged. Please contact the hotline (see section 15 Contact).



Note!

Comply with applicable occupational safety and environmental protection regulations during installation, operation, maintenance, and repair.

3 Illustration of the “snorkel effect” principle

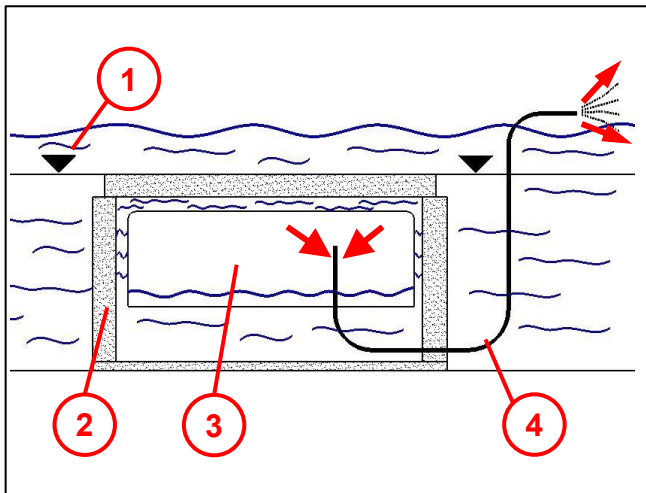

Fig. 1



Ensure that supply and discharge cables/lines (4) are tightly sealed to prevent a “snorkel effect” in rising water.

- 1 Ground level
- 2 Underground distribution system
- 3 Tray/flood-proof cover

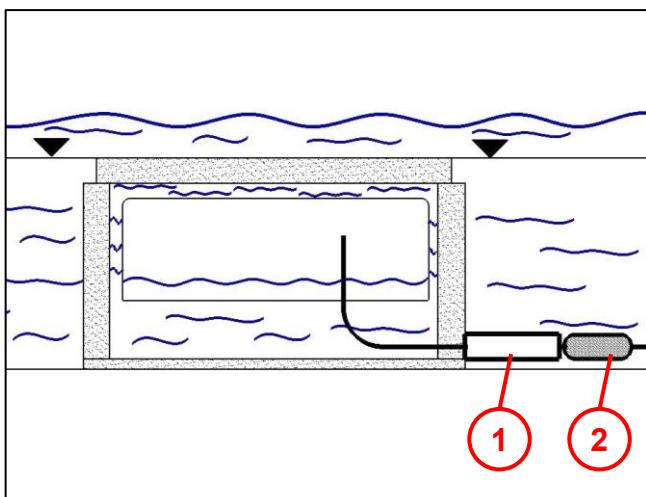

Fig. 2

The seal must be gas-tight.

- Use compression joints with an oil stop, for example.
- Then encase the cable using a cast resin fibre closure (2).

Fibre enclosures outside the underground distribution system:

Note!

- Do not lay cables directly in the ground!
- A conduit (1), among other things, can be used to protect cables!

4 Product description

The EK880 | EK890 underground distribution system is mainly designed for low-voltage energy distribution and for accommodating electronic components. The flood-proof cover of the underground distribution system is lowered into the ground when not in use and can be conveniently extended using a gas-pressure spring if needed.

The underground distribution system can be configured for two different applications for each cover:

- For energy distribution: Accommodation of up to six NH switch disconnecter fuses and/or fuse bases with a width of 100 mm. Fixtures are connected with cables coupled to the grounding cable outside the manhole.
- For housing of electronic components: The sturdy flood-proof stainless steel cover safely houses and protects 19" RU electronic components or electronic components on a mounting panel.

A closed door, which can also be locked, prevents small animals from entering.

The system thus provides a tailor-made, simple and safe power supply or accommodation for electronic components. This cutting-edge underground distribution system is designed for rapid installation and simple maintenance for guaranteed cost-effectiveness. The equipment is safely protected and accommodated, hidden in the soil. Vandalism problems are now a thing of the past.

4.1 Technical data

The EK880 and EK890 variants are available in configurations with four or five frame levels.

Version		EK880	EK890
External dimensions (with hook)		1240 x 1580 mm	954 x 1342 mm
Clear dimensions:		800 x 1400 mm	650 x 1165 mm
Overall depth in the ground:		1105 mm + 220 mm with 5 frames	
Height with the cover folded up above ground:		1080 mm	
Operating voltage when used for energy distribution		1,000 V AC	
Manhole cover		Cast-iron swivel cover	-
		Concrete-lined cover	
		Paveable cover	
Load class		D400	
Material of the manhole body		PC	
Nominal rated voltage for electrical distribution:		1,000 V DC	
Underground distribution system protection class	Door without ventilation grille	folded down	IP 48
		folded up	IP 44
	Door with ventilation grille	folded down	IP 47
		folded up	IP 41

4.2 Package includes

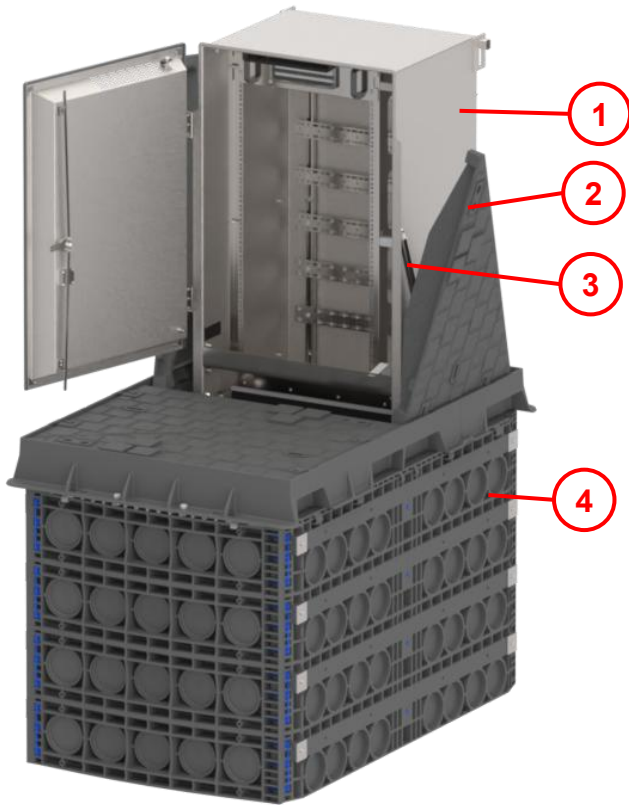

Item 1 Cover with door

Item 2 Triangular cover

Item 3 Gas springs

Item 4 Manhole body
(Frame quantity depending on the scope of supply)

Fig. 3

4.3 Required tools

4.3.1 Included



1



2

1 EJ triangular cover key
700847800

2 Operating tool / lifting tool
700849300

Fig. 4

4.3.2 Not included



3



4



5

3 Hammer

4 Socket wrench

5 AF 8 hex key

Fig. 5

5 Foundation pit base

5.1 General

- The underground distribution system must be installed by a qualified expert company.
- The soil conditions must be assessed before preparing a load-bearing foundation pit base.
 - The manhole must be installed in “non-cohesive” to “cohesive” mixed soils.
 - Groups G1 to G3 soil types as per ATV-DVWK-A 127 (German Association for Water, Waste Water and Waste), and/or soil groups GE, GW, GI, SE, SW, SI, GU, GT, SU, ST, GU*, GT*, SU*, ST*, UL, and UM as per DIN 18196.



Caution!

Observe ZTV A-StB 12 (Supplementary Technical Contract Conditions and Guidelines for the Construction of Asphalt Roads) for the construction of the road surface!

5.2 Preparing the foundation pit base

When preparing the foundation pit, comply with the following documentation from the Gütegemeinschaft Leitungstiefbau e.V. (Underground Cable Line Construction Quality Association):

"Procedural instructions for performing tasks in underground cable line construction".

Ensure that the position and depth of the foundation pit base matches the installation situation.

Make sure that the upper edge of the manhole cover lies completely flush with the surrounding ground level and does not project.

Align the cover surface horizontally. No height adjustment is possible with this product.

5.2.1 Drainage

The water drainage system is connected via a predetermined breaking point in the lowest frame. Installation of a backflow trap between the water drainage connection and waste water system is recommended.

Drain any water that has penetrated into the manhole to a surface drainage system (e.g. gravel).

5.2.2 Possible situations for the foundation pit base

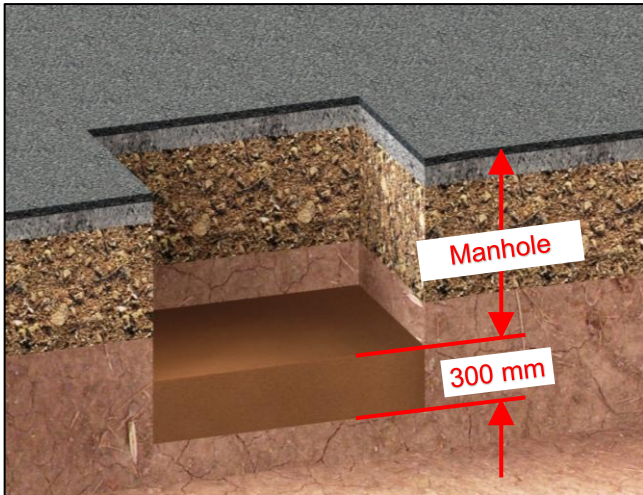

Fig. 6

Situation A

For pedestrian areas:

- Use an underfill/bottom layer with a minimum thickness of 300 mm.
- The underfill/bottom layer must consist of “non-cohesive” to “cohesive” mixed soil (group G1 soil type as per ATV-DVWK-A127).
- Layer and compact the underfill/bottom layer to $D_{Pr} \geq 98\%$.

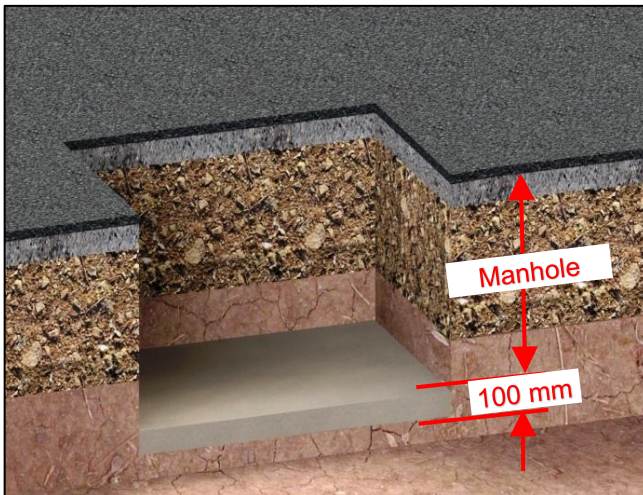

Fig. 7

Situation B

For vehicle traffic areas:

- Compact the pit base according to the requirements.
- With group G1/G2 soil types as per ATV-DVWK-A 127 (soil groups GE, GW, GI, SE, SW, SI, GU, GT, SU, ST as per DIN 18196):
- Lay a concrete load-bearing layer at least 100 mm thick (tamped concrete, strength class $\geq C8/10$).

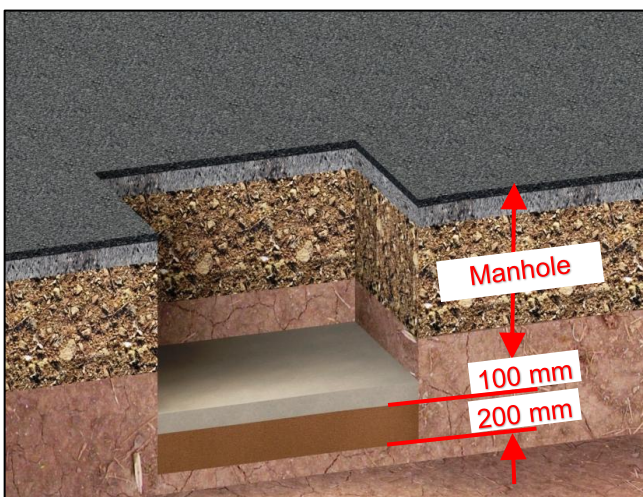

Fig. 8

Situation C

For vehicle traffic areas:

- With group G3 soil type as per ATV-DVWK-A 127 (soil groups GU*, GT*, SU*, ST*, UL, UM as per DIN 18196):
- Lay an underfill of group G1 soil types as per ATV-DVWK-A 127. Minimum thickness 200 mm. Layer and compact the underfill to $D_{Pr} \geq 98\%$.
- Lay a concrete load-bearing layer at least 100 mm thick (tamped concrete, strength class $\geq C8/10$).

6 Installation

6.1 Preparing the underfloor distribution system

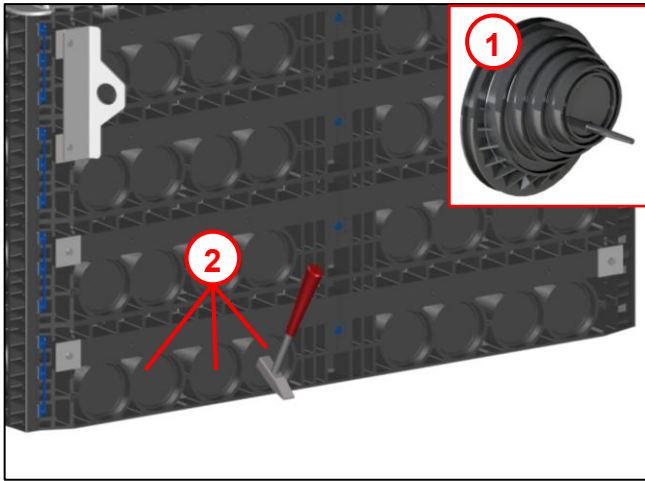

Fig. 9

- Establish the required number and position of cable ducts.
- Knock out the relevant predetermined breaking points (2) with a hammer.
- Remove any burrs with a suitable tool.
- Using a suitable tool, open up the required pipe diameter in the predetermined breaking points for the stepped grommet supplied (1).
- Insert the stepped grommet into the opening in the manhole.

6.2 Inserting the underground distribution system

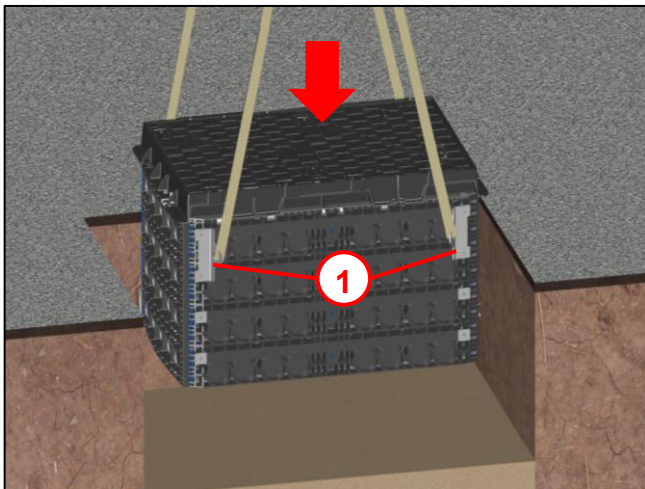

Fig. 10

- Place the manhole on the foundation pit base.



Warning:

- Use slings or similar to insert the manhole.
- Suspend the slings on the attached crane lugs (1).
- Risk of injury due to the manhole tipping and falling!

6.3 Opening the triangular cover

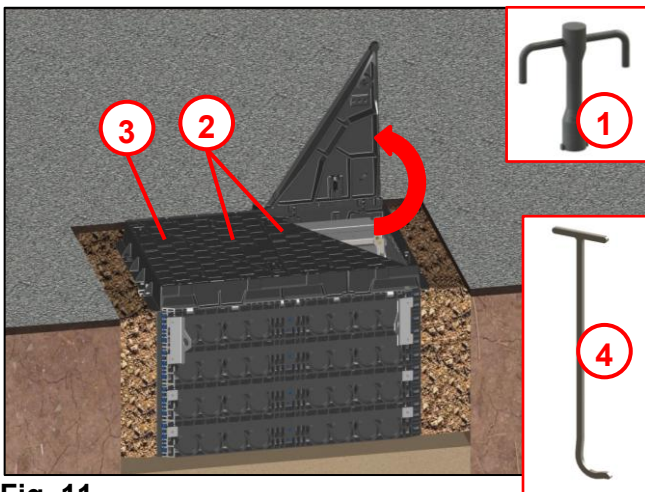

Fig. 11

- Using the key supplied (1), unlock the first triangular cover and lift it up as far as the automatic fastening clamp.
- The two middle covers (2) and the outer cover (3) can now be opened as well using the hook supplied (4) (overlap-underlap).



Attention!

Check the fastening clamp! Risk of injury due to body parts being crushed!

6.4 Grounding

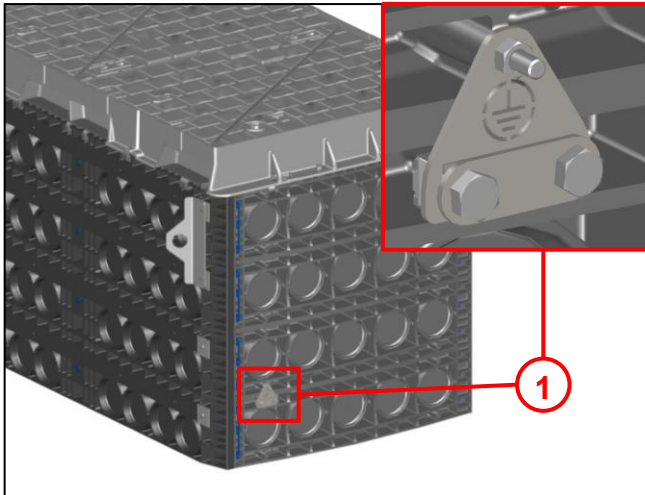

Fig. 12

- Grounding **(1)** on the outside of the underground distribution system.

6.5 Closing the triangular covers

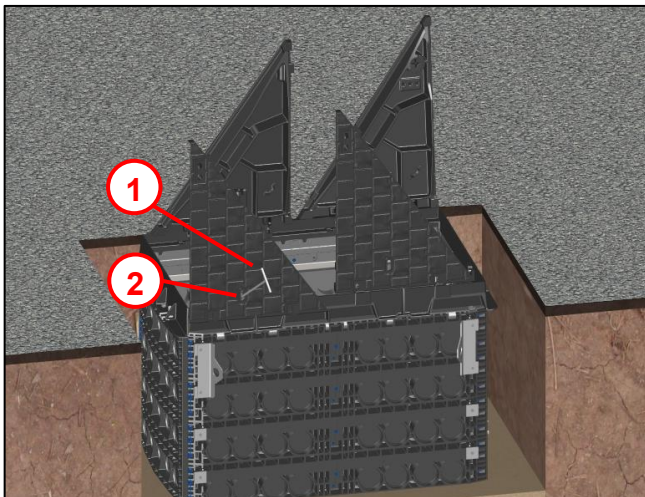

Fig. 13

- Close the triangular covers in reverse order (overlap-underlap).
- To do so, slot the hook **(1)** into the lifting opening **(2)**.
- Pull the internal spring upwards.
- This loosens the fastening clamp of the triangular cover.

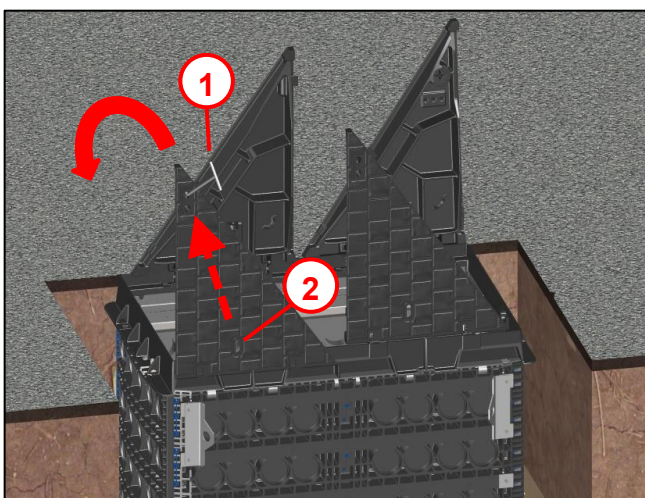

Fig. 14

- Remove the hook **(1)** from the lower lifting opening **(2)** and hook it into the upper lifting opening.
- Carefully lower the triangular covers.



Caution!

Risk of injury due to body parts being crushed

6.6 Fitting the protective pipe seals

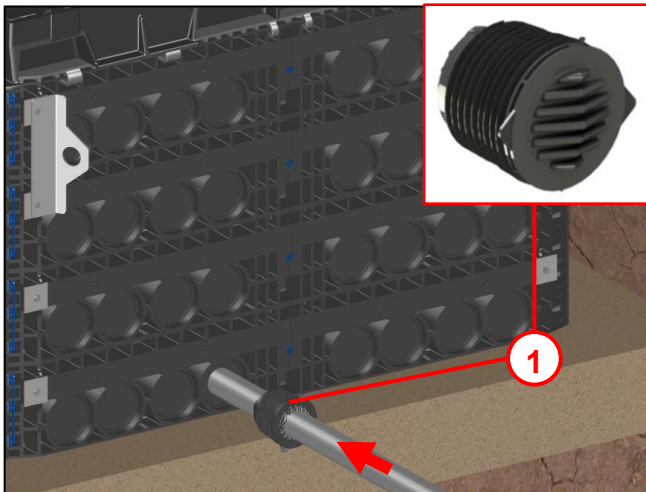

Fig. 15

To prevent the manhole from silting up, we recommend using a protective pipe seal **(1)** when laying grounding cables.

7 Constructing the surrounding surface

7.1 Backfilling the foundation pit up to the lower edge of the top layer

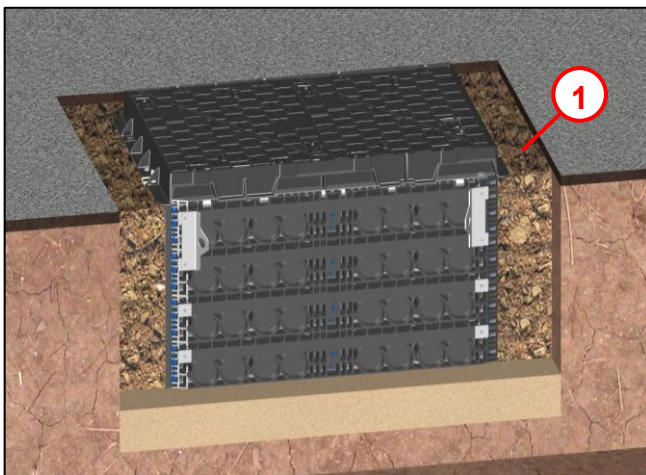

Fig. 16

- Backfill and compact the foundation pit in layers using material suitable for compacting **(1)** in accordance with ZTV E-StB 09 up to the lower edge of the top layer.

7.2 Removing the triangular covers

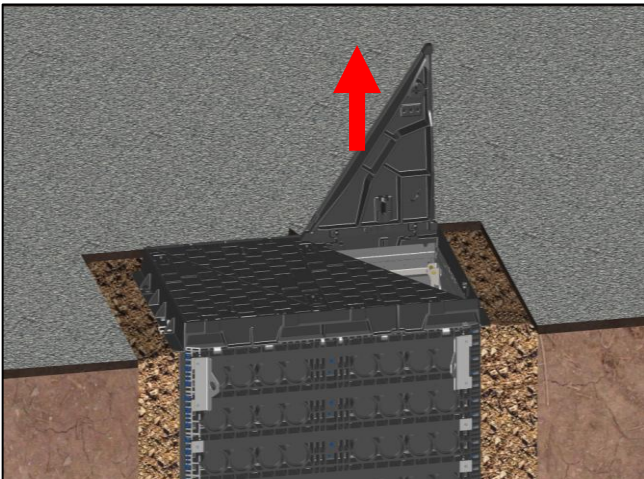

Fig. 17

- Open the triangular covers (see section 6.3).
- Lift all triangular covers individually out of their hinges and set aside.

7.3 Lifting the cast-iron frame

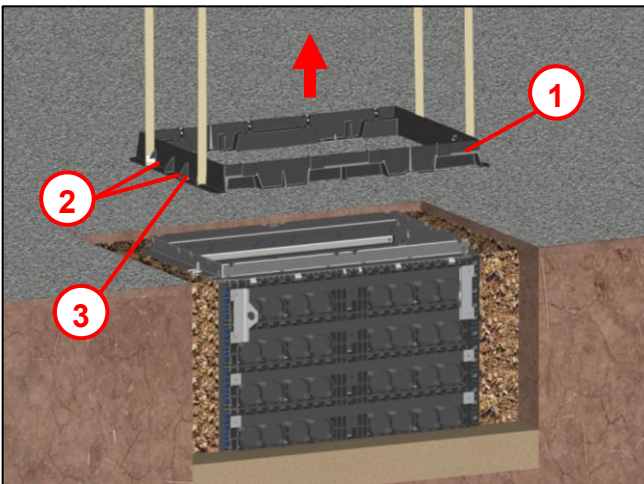

Fig. 18

- Loosen the 4x M12 hex screws (2).
- Lift the cast-iron frame (1).



Warning:

- Use the lugs (3) on the cast-iron frame to do this.
- Risk of injury due to body parts being crushed.

7.4 Fitting the height adjustment hole plug

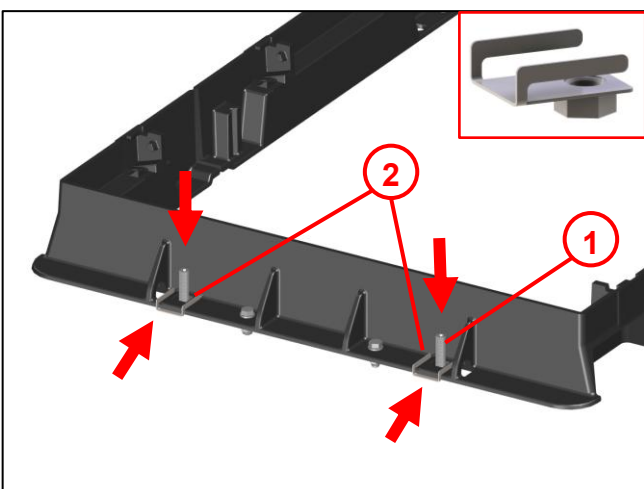

Fig. 19

- Attach the 4x height adjustment clamps (2) to the square opening in the cast-iron frame.
- Screw in 4x M16x70 threaded spindles (1) from above through the cast-iron frame into the height-adjustment clamps (2).
- Replace the cast-iron frame onto the plastic manhole.

7.5 Adjusting the height

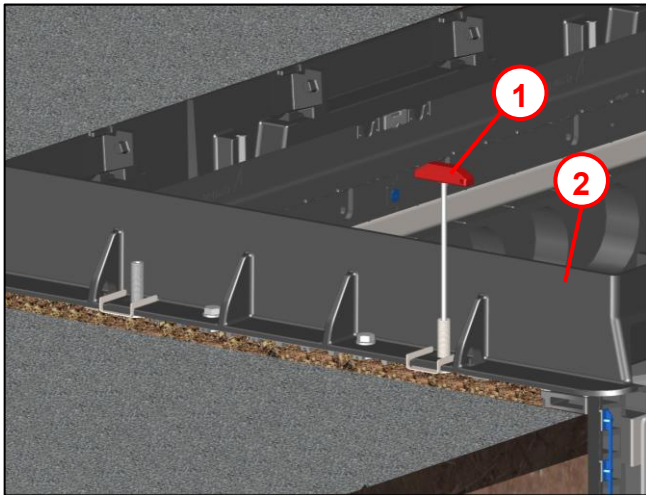

Fig. 20

- Turn the M16x70 threaded spindles (1) at all four positions to lift the cast-iron frame (2) and adjust it to its intended height.

Note:

Adjustment range approx. 50 mm.

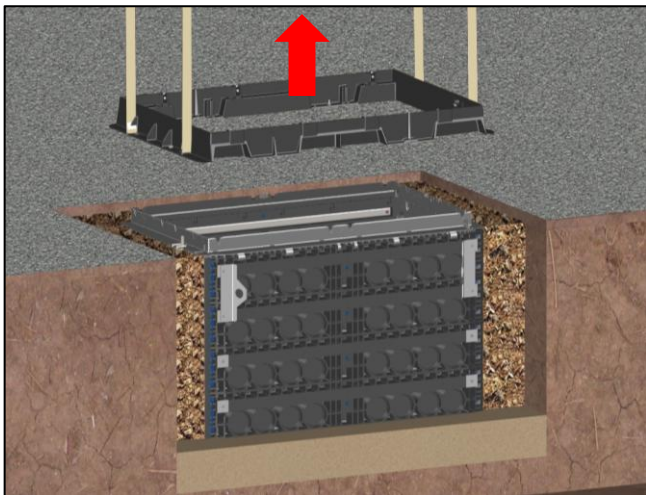

Fig. 21

- Remove the cast-iron frame again.

7.6 Filling the height-adjustment gap

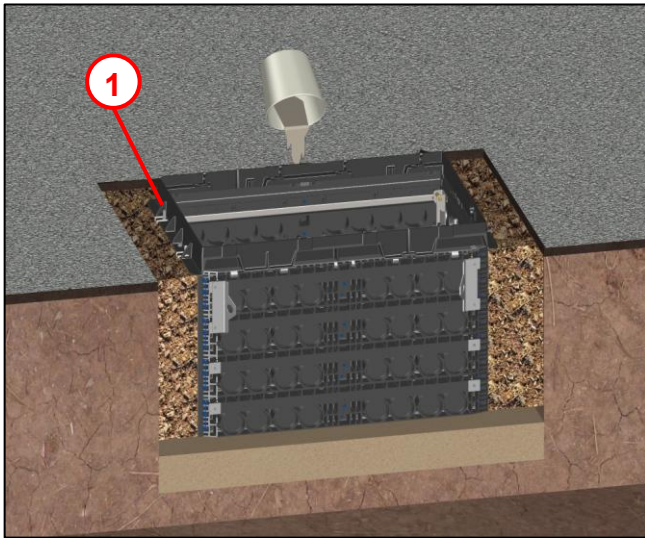

Fig. 22

- A dry or casting mortar is applied to the plastic top frame (1) to backfill the height-adjustment gap. A formed shuttering wall on the top frame prevents the dry or casting mortar from seeping inwards.
- Backfill according to DIN 18555
- Compressive strength: $>35 \text{ N/mm}^2$ after 28 days.
- Dry mortar: e.g. type Kombina 35S or similar.
- Casting mortar: e.g. AzKm
- Supplier: Ergelit in Alsfeld

Note:

Do not use foam to fill in the gap! It does not meet load capacity requirements!

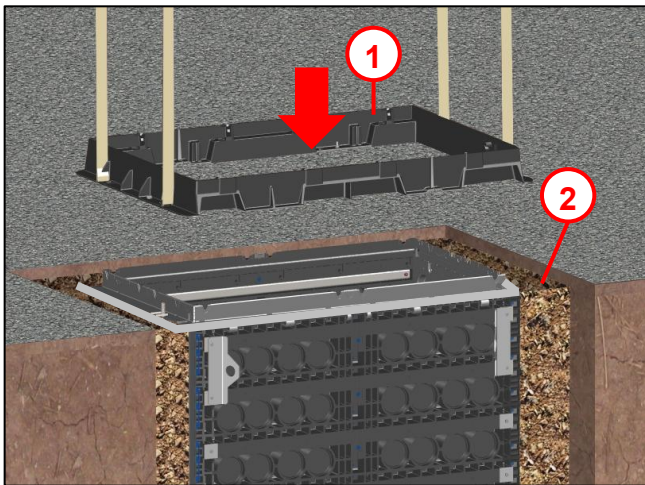

Fig. 23

- Once the mortar has been applied to the cast-iron frame (1), replace it onto the manhole until the upper edge of the cast-iron frame forms a seal with the top layer (2).

7.7 Inserting the triangular covers

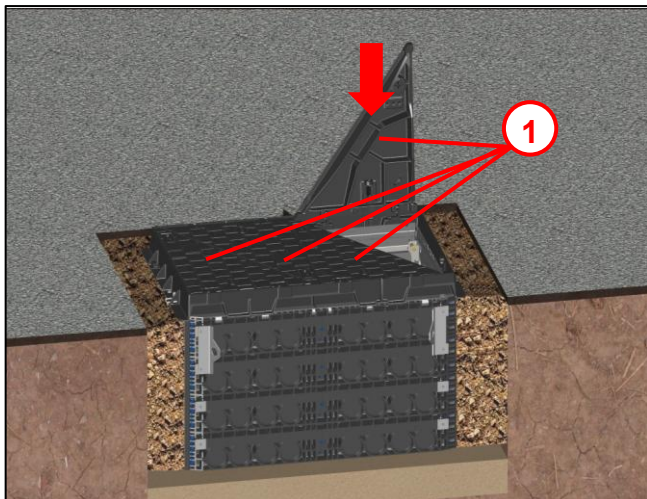

Fig. 24

7.8 Constructing the top layer

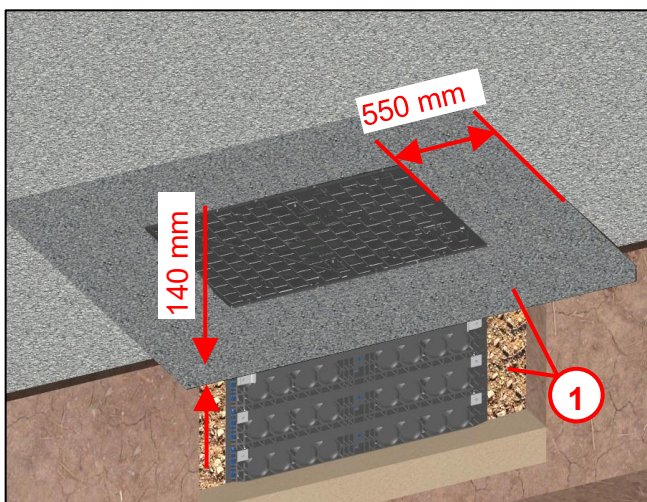

Fig. 25

- Refit the triangular covers **(1)** individually into their hinges.
Note: The triangular covers need to be inserted in their original positions!
- Close the triangular covers (see section 6.5).
Note: Only exert loading on the manhole once the dry/casting mortar used has reached the strength specified by the manufacturer!

- Construct the top layer **(1)** as per ZTV A StB 12 (or RStO 2001).
- At the upper edge of the top layer, allow a strip of concrete or poured asphalt at least 550 mm wide and 140 mm thick (asphalt base layer of at least construction class V according to RStO 2001).

8 Operation

8.1 Swivelling out the cover

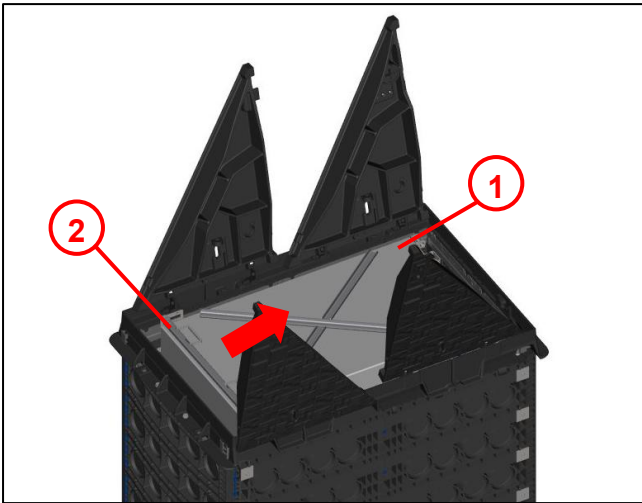

Fig. 26

- Unlock the cover (1).
- Slide the locking rod towards the middle of the cover.

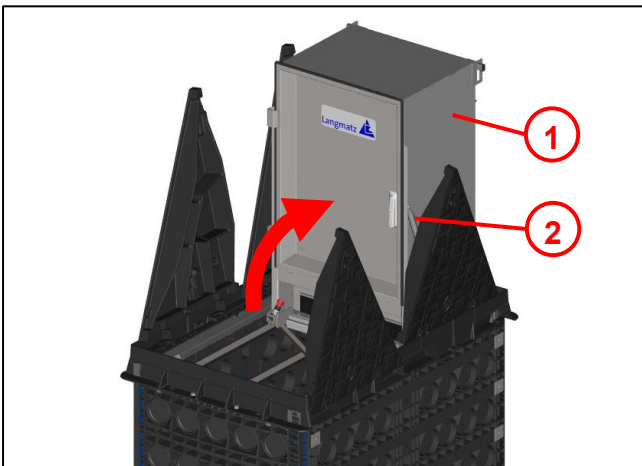

Fig. 27

- Lift up the cover (1) with the help of the gas springs (2) until the lock stop audibly engages on the lower edge of the cover.

Note: Gas springs are only intended as an aid.

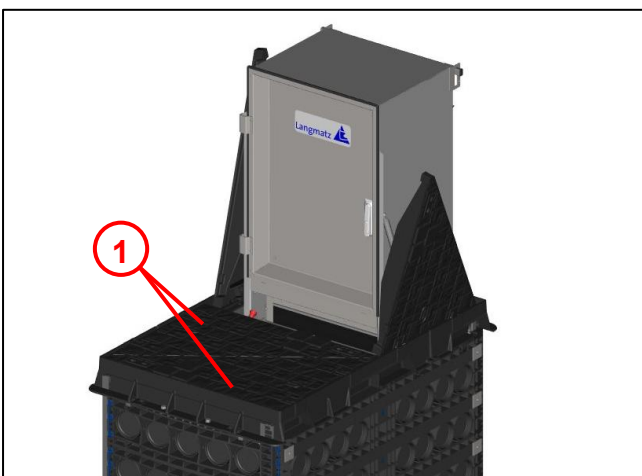
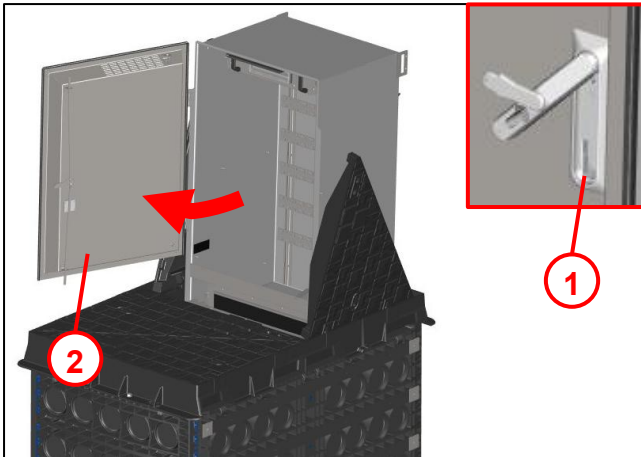

Fig. 28

- Install the operator platform.
- Close the two front covers (1).

8.2 Opening the cover



- Open the turning lever (1).
- Open the door (2).

Fig. 29

8.3 Swivelling in the cover

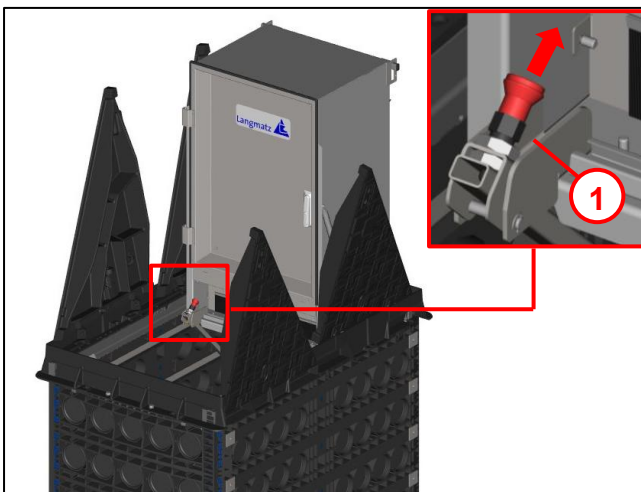

- Close the door.
- Close the turning lever.
- Open the two front covers.
- Pull the locking bolt (1), unlock it, and fold down the cover.

Fig. 30

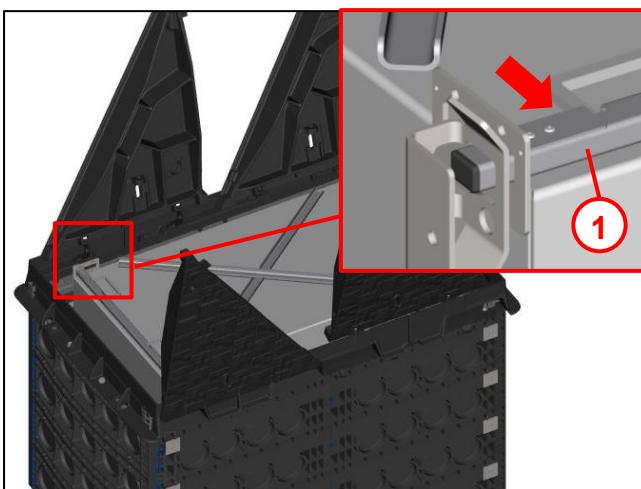

- Lock the cover by moving the locking rod (1) parallel towards the end of the cover.



Fig. 31

9 Maintenance

9.1 General measures

Measures	Intervals	Remarks
Clean the interior of the underground distribution system	After every use	By trained professionals
Check that the fastening screws fit securely	Annually	
Open and close the swivel cover	Every six months	Regularly operate the gas springs to lubricate the seals.
Visual inspection of the drain for free drainage	After every use	
Check that the fastening clamp is working when the triangular covers are open	Each time the cover is opened	Clean the fastening clamp if it cannot be properly fastened.

10 Accessories

No.	Name	Article number	Figure
1	Protective pipe seal Ø110 mm	081863110	
2	Key for EJ triangular cover	700847800	
3	Operating tool / lifting tool	700849300	

11 Declaration of Conformity

The product meets the requirements of the following applicable harmonisation directives:

2006/42/EC Machinery Directive

Compliance with the relevant harmonisation legislation has been demonstrated through the application of the following harmonised standards:

No applicable harmonised standards exist.

Compliance with the harmonisation legislation has been demonstrated through the application of the following other standards and technical specifications:

DIN EN 124-1: 2015-09 (not harmonised)

DIN EN 124-3: 2015-09 (not harmonised)

12 Material defects

Langmatz GmbH accepts liability for material defects in the product as per Section 434 BGB (German Civil Code) for 24 months, starting from the date on the purchase receipt.

Within the scope of liability, all parts that become damaged due to manufacturing faults or material defects will be replaced or repaired free of charge.

The purchaser must report any deficiency complaints immediately in writing.

Claims by the purchaser for damages due to material defects or for whatever legal reason will not be accepted.

Any damage or failure caused by the following are also excluded from liability

- Incorrect use,
- Natural wear and tear
- Intervention by third parties.

We accept no liability for damage caused by force majeure or transport.

Repairs due to a complaint about a defect do not extend the warranty period for the replaced parts or for the product.

This product conforms to the latest state-of-the-art technology. Nevertheless, if you experience any problems with it, please contact our hotline (see section 15 Contact).

13 Quality management

The Langmatz GmbH quality management system is certified to DIN EN ISO 9001.

14 Disclaimer/Warranty

The information in this technical document is presented appropriately and correctly in compliance with the technical regulations, and to the best of our knowledge. However, this does not confer any guarantee of particular characteristics. In this context, the company that operates the products supplied by Langmatz GmbH is expressly obliged to decide, based on its own judgement, whether the products are suitable and appropriate for the application or use being considered. The product liability accepted by Langmatz GmbH relates exclusively to our conditions of sale, delivery, and payment. Langmatz GmbH accepts no liability on the basis of random, indirect and resultant consequential damage, or of any damage attributable to any use of the product other than its intended purpose as described.

15 Contact

Langmatz GmbH | Am Gschwend 10
82467 Garmisch-Partenkirchen, Germany

Our hotline: +49 88 21 920 – 137

Phone: +49 88 21 920 – 0

E-mail: info@langmatz.de | www.langmatz.de

