

1	General information	3
2	Safety information	3
3	Product description	4
3.1	Dimensions	4
3.2	Technical data	4
3.3	Operating voltages.....	5
4	Required tools	5
5	Changing the fan unit	5
6	Commissioning	6
7	Function test.....	8
8	Fan supply outlets.....	9
9	Maintenance.....	9
10	EU Declaration of Conformity.....	10
11	Material defects.....	11
12	Quality management.....	11
13	Disclaimer/Warranty	11
14	Contact	11

1 General information

These instructions are supplied with the equipment.



Note!

Any person involved in assembly, operation, maintenance and repair of the product must first read, understand and follow these instructions. We accept no liability for damage and operating malfunctions caused by failure to comply with these instructions.

In the interest of further development, we reserve the right to change individual assemblies and accessories as considered necessary for further safety and performance improvements, while preserving the main features.

The copyright to these instructions remains with Langmatz GmbH.

2 Safety information

The product corresponds to the latest state-of-the-art technology at the time of printing and is delivered in an operationally safe condition.

Unauthorised modifications, particularly to safety-related parts, are prohibited.

The operator is responsible for installing, operating and maintaining the fixtures.

The operator has to take care of that:

- Preventing danger to life and limb of users and third parties.
- Ensuring safe operation.
- Precluding downtime and environmental impact due to incorrect handling.
- Ensuring that protective clothing is worn when working with or on the product.



Do not use the product if it is damaged. Please contact the hotline.



Note:

Applicable occupational-safety and environmental-protection regulations must be observed during installation, operation and maintenance or repair.

3 Product description

3.1 Dimensions

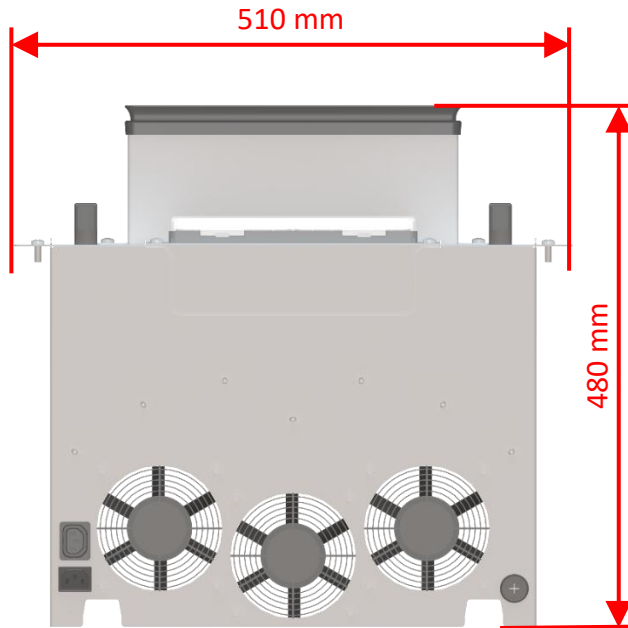

Fig. 1

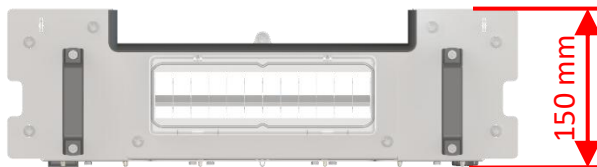

Fig. 2

3.2 Technical data

Housing material	Stainless steel
Protection class	I
Degree of protection	IP47
Power consumption	Typically 36 W maximum 54 W
Ambient temperature	-25°C to +38°C
Weight	Approx. 8 kg
Connection cable	3x 1.5 mm ²
Adjustable / switching point	-15 ° - +45 °
Hysteresis / threshold value	0.5 – 5 degrees
Design verification	As per DIN 61439-1
Control power of heat extraction	Max. 180 watts
Power supply unit	Power 60 watts / 24 VDC
Per fan	24 VDC / 12 watts
Air flow per fan	285 m ³ / h
Noise level	55 dB per fan
Fan speed	5000 rpm

3.3 Operating voltages

Designation	Core	Minimum	Maximum	Unit
Permanent operating voltage	1/2		230 V / AC	volts
Fan assembly input power			Max. 54	watts

4 Required tools



Fig. 3

Small cross-head screwdriver
Large cross-head screwdriver

5 Changing the fan unit

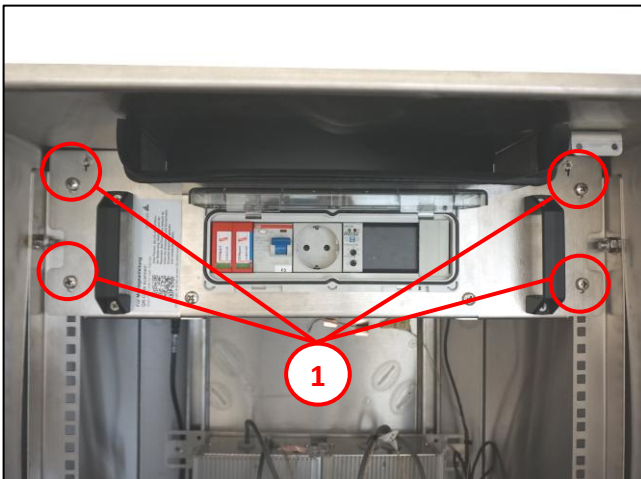

Fig. 4

- Loosen 4 x cross-head screws **(1)**.

Note: disconnect the unit from the mains voltage before removing it!

6 Commissioning

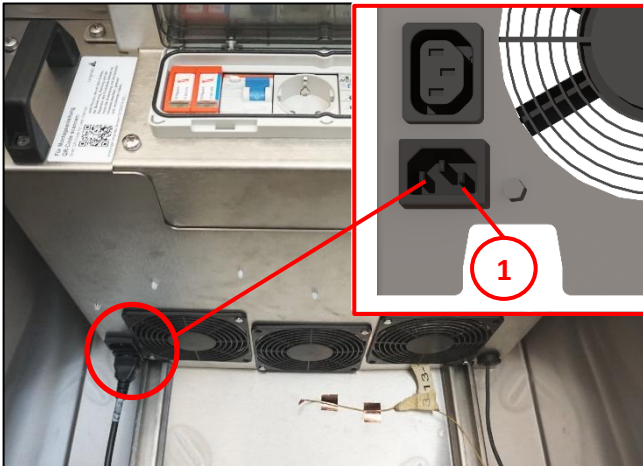

Fig. 5

- Power the cold-device plug input with 230 VAC operating voltage.

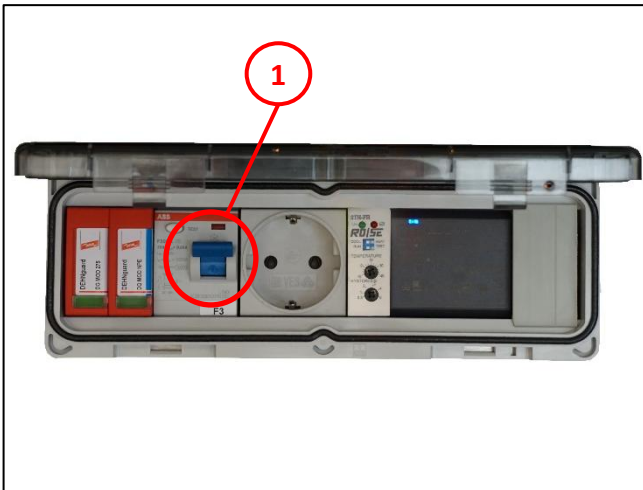

Fig. 6

- Actuate the residual current device (1).

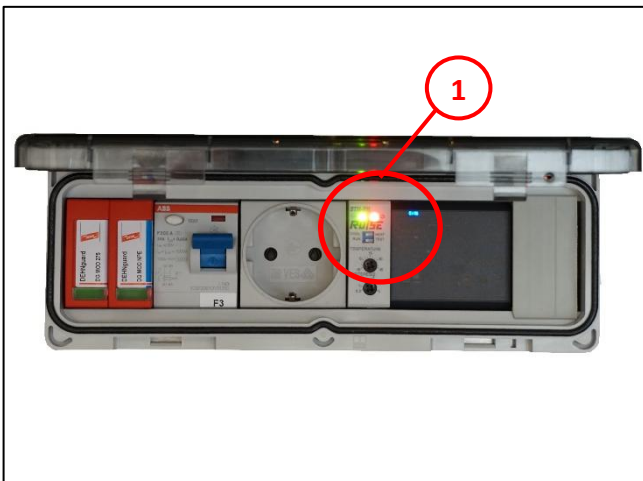

Fig. 7

- Green LED from the control element and blue LED from the power supply unit light up (red LED does not).

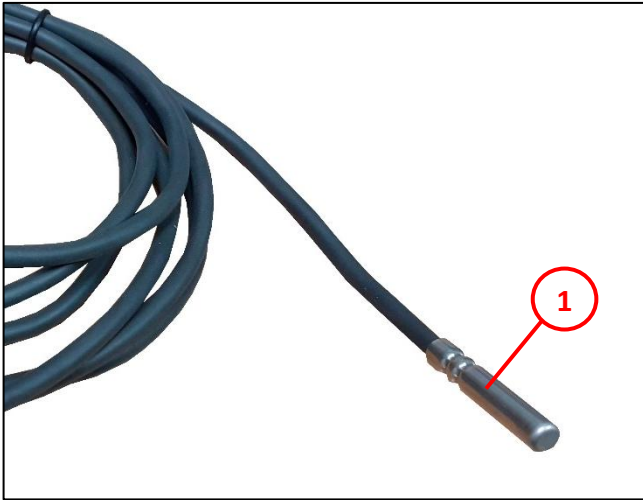

Fig. 8

- Place the temperature sensor **(1)** in the device at the hottest point.

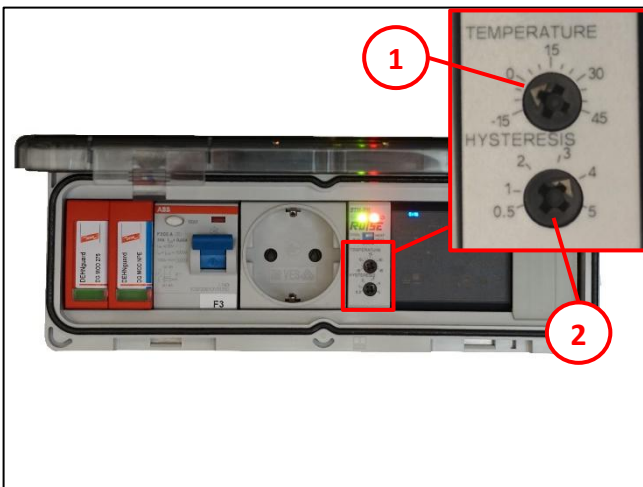

Fig. 9

- Set the desired temperature for the starting point of ventilation and hysteresis **(2)** on the control element **(1)** with a small cross-head screwdriver.

7 Function test

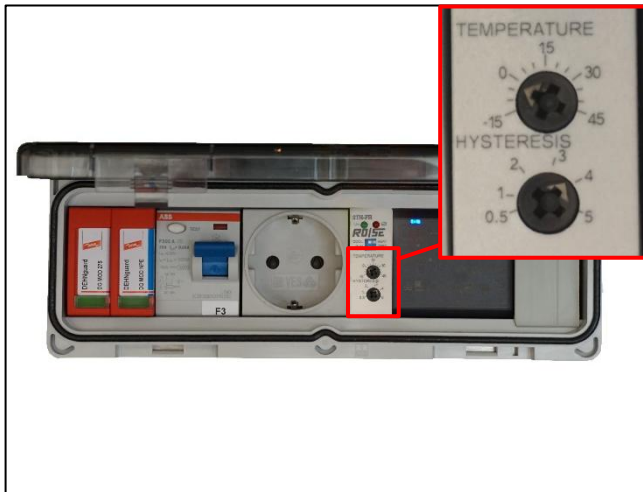

Fig. 10

- Higher temperature at the installation site than setting on the control element.
→ Fans start / Red LED lights up

- Lower temperature at the installation site than setting on the control element.
→ Fans stop / Red LED goes out

(e.g. outdoor temperature 20 °, setting on the control element 15 °. Fans run until the control temperature of 15 ° is reached)



Note:

Selector switch must be set to COOL and RUN, otherwise the switch-on point (heating or cooling) is inverted!



Note:

Fitting air filters in the inlet of the fans reduces the control performance of the assembly.

8 Fan supply outlets

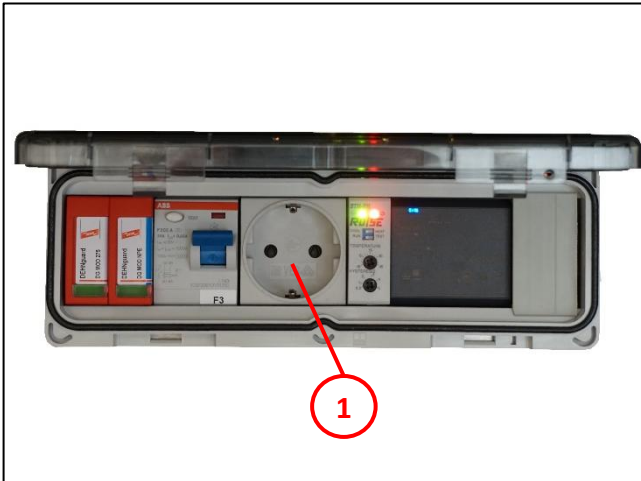

Fig. 11

- Service socket (1) outlet side / fused via RCD/circuit breaker.

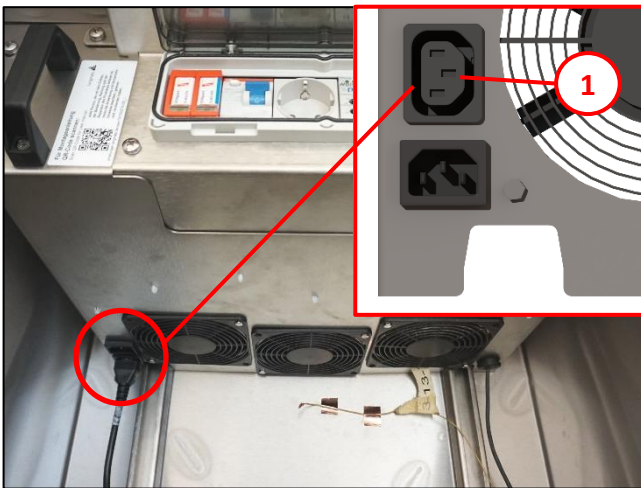

Fig. 12

- Cold-device socket (1) outlet side / fused via RCD/circuit breaker.

9 Maintenance

Measures	Intervals	Remarks
External visual inspection	At least every 12 months or during maintenance measures on the complete installation.	Check the device for external dirt and damage. Note: do not use abrasive cleaning agents or solvents to clean the housing.
Carry out a complete function test (see Chapter 7)		In the event of a defect, send the device with a description of the fault to Langmatz GmbH.

10 EU Declaration of Conformity

The product meets the requirements of the following applicable harmonisation directives:

2014/35/EU Low Voltage Directive (LVD)

The following standards were complied with:

DIN EN 61439-1:2012-06
DIN EN 61439-2:2012-06

The EU Declaration of Conformity for this product can be requested from Langmatz GmbH.

11 Material defects

Langmatz GmbH accepts liability for material defects in the product as per Section 434 BGB (German Civil Code) for 24 months, starting from the date on the purchase receipt.

Within the scope of liability, all parts that become damaged due to manufacturing faults or material defects will be replaced or repaired free of charge.

The purchaser must report any deficiency complaints immediately in writing.

Claims by the purchaser for damages due to material defects or for whatever legal reason will not be accepted.

Any damage or failure caused by the following are also excluded from liability

- Incorrect use,
- Natural wear and tear
- Intervention by third parties.

We accept no liability for damage caused by force majeure or transport.

Repairs due to a complaint about a defect do not extend the warranty period for the replaced parts or for the product.

This product conforms to the latest state-of-the-art technology. Nevertheless, if you experience any problems with it, please contact our hotline (see section 14).

12 Quality management

The Langmatz GmbH quality management system is certified to DIN EN ISO 9001.

13 Disclaimer/Warranty

The information in this technical document is presented appropriately and correctly in compliance with the technical regulations, and to the best of our knowledge. However, this does not confer any guarantee of particular characteristics. In this context, the company that operates the products supplied by Langmatz GmbH is expressly obliged to decide, based on its own judgement, whether the products are suitable and appropriate for the application or use being considered. The product liability accepted by Langmatz GmbH relates exclusively to our conditions of sale, delivery, and payment. Langmatz GmbH accepts no liability on the basis of random, indirect and resultant consequential damage, or of any damage attributable to any use of the product other than its intended purpose as described.

14 Contact

Langmatz GmbH | Am Gschwend 10

82467 Garmisch-Partenkirchen, Germany

Our hotline: +49 88 21 920 – 137

Phone: +49 88 21 920 – 0

E-mail: info@langmatz.de | www.langmatz.de