

Installation instructions

Langmatz optical fiber transfer system distribution and termination box L 3.0
ONT L 3.0 pre-assembled



Contents

<u>1</u>	<u>General information</u>	<u>3</u>
<u>2</u>	<u>Safety information</u>	<u>3</u>
<u>3</u>	<u>Product description</u>	<u>4</u>
	<u>3.1 Dimensions</u>	<u>4</u>
	<u>3.2 Technical data</u>	<u>4</u>
<u>4</u>	<u>Package includes</u>	<u>5</u>
<u>5</u>	<u>Step 1 – Installing the cabinet on the wall</u>	<u>6</u>
	<u>5.1 Required tools (not included)</u>	<u>6</u>
	<u>5.2 Dimensions for mounting holes</u>	<u>6</u>
	<u>5.3 Fastening the cabinet on the wall</u>	<u>7</u>
	<u>5.4 Example: Guiding the micro-duct pipe outwards</u>	<u>7</u>
<u>6</u>	<u>Step 2 – Commissioning</u>	<u>8</u>
	<u>6.1 Required tools (not included)</u>	<u>8</u>
	<u>6.2 Opening the seal</u>	<u>8</u>
	<u>6.3 Opening the cover</u>	<u>8</u>
	<u>6.4 Attaching the LC-APC patch cable</u>	<u>9</u>
	<u>6.5 Inserting the LC-APC patch cable into the port seal</u>	<u>10</u>
	<u>6.6 Layout plan – Optical fibre cables</u>	<u>10</u>
	<u>6.7 Complete port seal</u>	<u>11</u>
	<u>6.8 Closing the cover</u>	<u>11</u>
<u>7</u>	<u>Material defects</u>	<u>12</u>
<u>8</u>	<u>Quality management</u>	<u>12</u>
<u>9</u>	<u>Disclaimer/Warranty</u>	<u>12</u>
<u>10</u>	<u>Contact</u>	<u>12</u>

1 General information

These instructions form an integral part of the delivery.



Note:

Any person involved in the installation and operation of the product must first read, understand and follow these instructions.



We accept no liability for damage and operating malfunctions caused by failure to comply with these instructions.

In the interest of ongoing development we reserve the right to make changes as considered necessary for further safety and performance improvements while preserving the main features.

The copyright of these instructions remains with Langmatz GmbH.

2 Safety information



- These installation instructions are addressed to technically trained expert personnel.
- All applicable accident prevention regulations and regulations for handling optical fibres must be observed!



- **Please note the possibility of laser radiation in the non-visible spectrum!**
- Never look into open fibre ends.

The operator is responsible for installing, operating and maintaining the fixtures.

The operator is responsible for the following:

- Preventing danger to the life and limb of users and third parties.
- Ensuring safe operation.
- Preventing downtime and environmental impact due to incorrect handling.
- Ensuring that protective clothing is worn when working with or on the product.



Use of a damaged product is prohibited. Please contact the hotline (see section 10).



Warning!

Comply with applicable occupational safety and environmental protection regulations during installation, operation, maintenance, and repair.

3 Product description

3.1 Dimensions

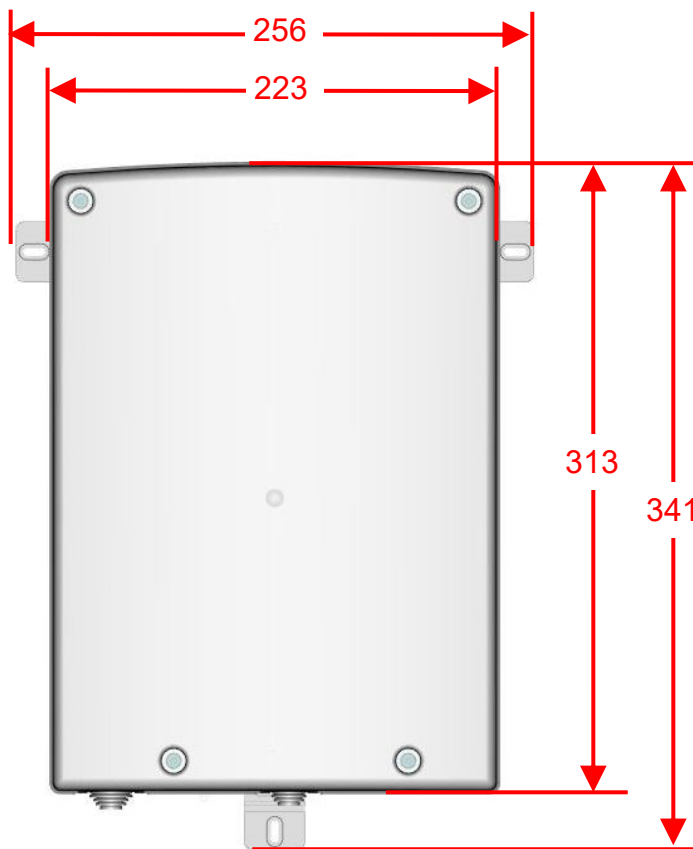

Fig. 1

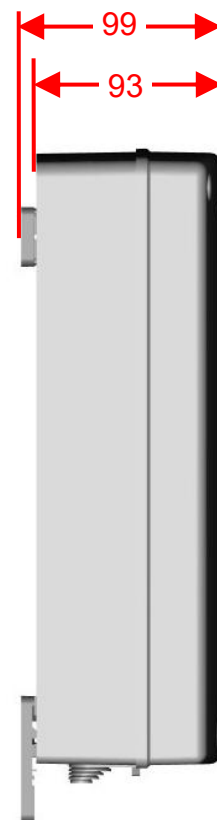

Fig. 2

3.2 Technical data

Dimensions W x H x D:	256 x 341 x 99 mm
Total weight	Approx. 1.1 kg
Cabinet material	Plastic – polycarbonate (PC)
Cabinet colour	Light grey RAL 7035
Protection rating	IP 54
Impact strength	IK 08
Fire protection class	UL94 V-2
Loop connector damping budget	3 dB ± 0.5

4 Package includes

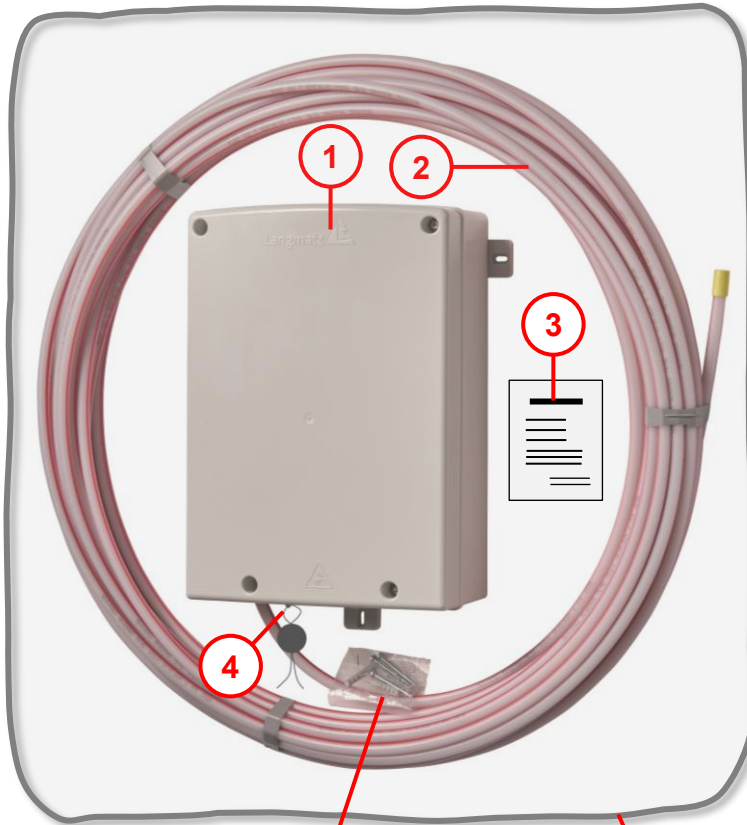

Fig. 3

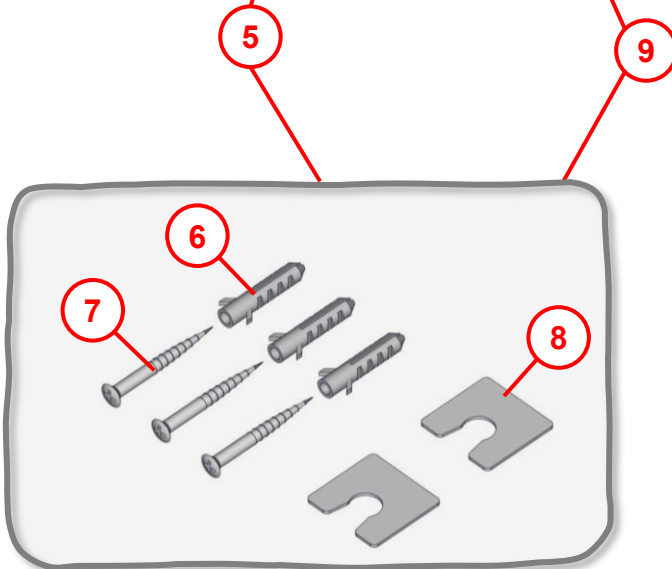

Fig. 4

Item 1 1x optical fibre transfer system distribution and termination box - L

Item 2 25 m micro-duct pipe
Ø10x2.0 mm
(fitted)

Note!

- Micro-duct pipe + 25 m internal optical fibre micro cable.
- Number of fibres = number of LC - APC connectors.

Item 3 1x measurement and test report

Note!

Retain the measurement and test report for safekeeping, and pass on to the service provider for further work processes.

Item 4 1x seal

Item 5 Accessories kit:

3x dowels S6 (6)
3x fastening screws
4x40 (7)

2x strain reliefs (8)
for micro-duct pipes Ø10
(Push and pull strain relief
in the optical fibre transfer
manhole)

Item 9 Bag

5 Step 1 – Installing the cabinet on the wall

5.1 Required tools (not included)



Phillips screwdriver PH2

Fig. 5

5.2 Dimensions for mounting holes

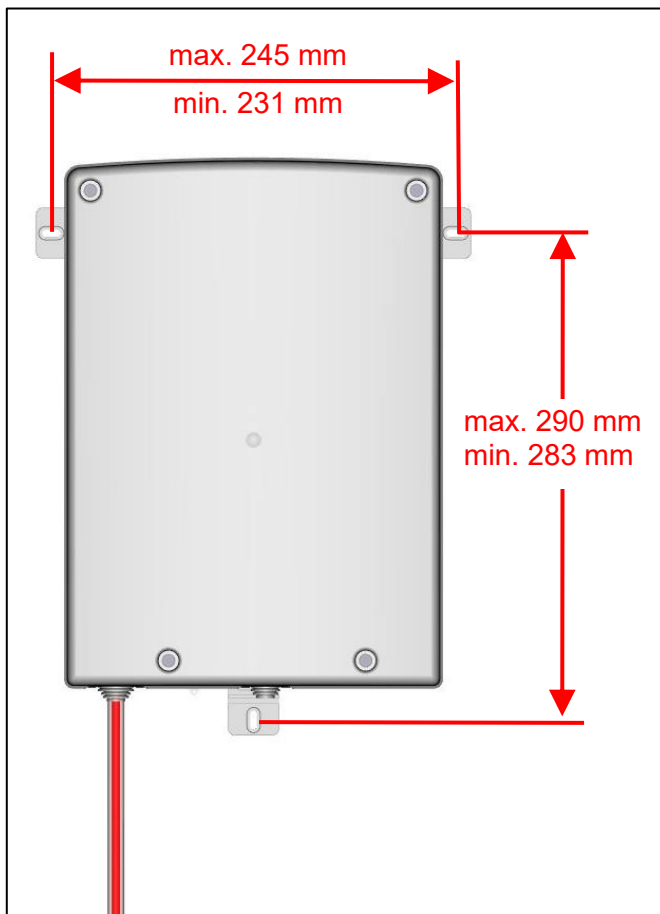

Fig. 6



Warning!

- Check for any existing lines in the wall prior to drilling (gas, water, power)!
- Risk of electric shock!

5.3 Fastening the cabinet on the wall

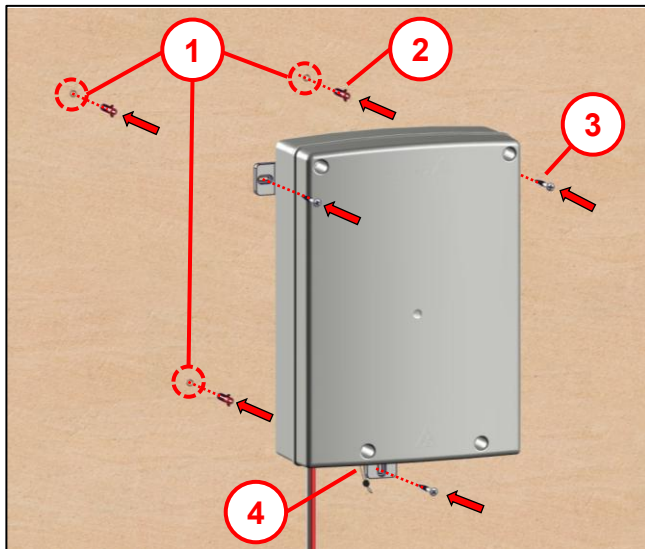

Fig. 7

Note!

Do not yet remove the seal (4)!
It is only removed during commissioning
(see section 6.2 “Step 2”).

- Drill 3 holes with a diameter of 6 mm (1).

From the accessories kit:

- Insert 3x dowels S6 (2) into the wall.
- Use 3x raised countersunk screws 4x40 (3) to fasten the cabinet to the wall.

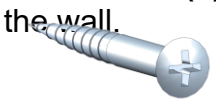

5.4 Example: Guiding the micro-duct pipe outwards

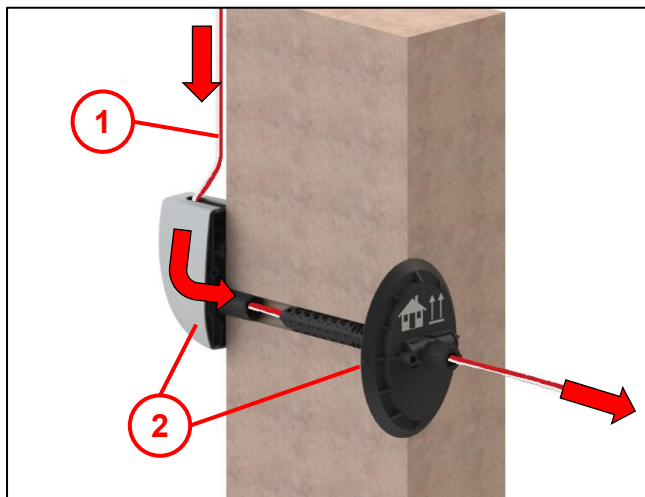

Fig. 8

- Once the optical fibre transfer system distribution and termination box - L has been installed, we recommend routing the micro-duct pipe (1) outwards solely through the Langmatz “VarioPipe optical fibre building cable & pipe entry system – that may be built over” (2).

(The optical fibre building cable & pipe entry system is not included with delivery.

Order it using
Langmatz art. no. 094592012).

6 Step 2 – Commissioning

6.1 Required tools (not included)

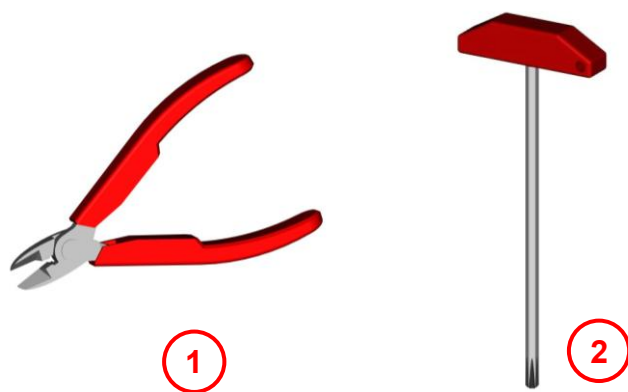

- 1 Cutter
(to open the seal)
- 2 Torx screwdriver T20
(to open the cover)

Fig. 9

6.2 Opening the seal

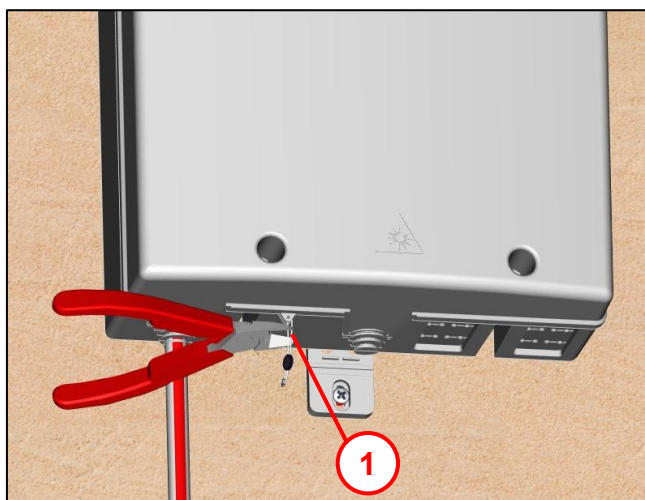

- On delivery, the cabinet is secured by a seal (1).
- Use a cutter to open the seal.

Fig. 10

6.3 Opening the cover

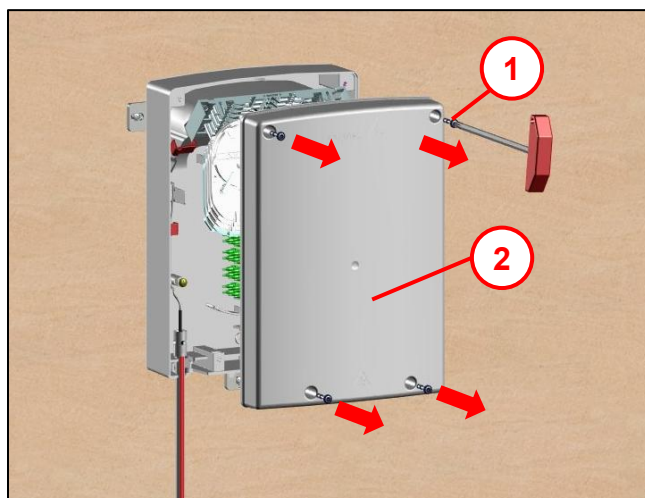

- Use a Torx screwdriver to unscrew 4x cover screws (1)
(Torz - M4)
and remove the cover (2).

Fig. 11

6.4 Attaching the LC-APC patch cable

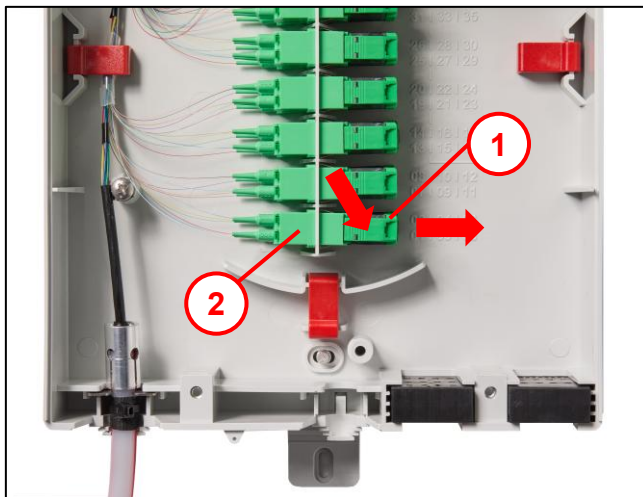

Fig. 12

Pre-installed couplers with loop connectors **(2)**.

- Press the 24x loop connectors **(1)** upwards and pull out downwards.

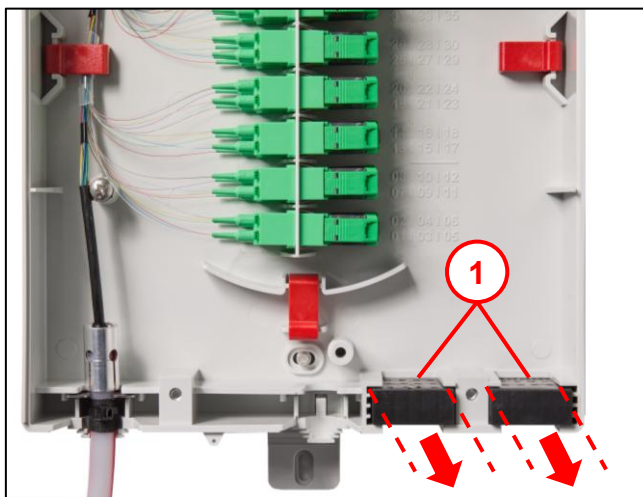

Fig. 13

This is prepared to make it easier to insert the optical fibre cables into the port seal **(1)**.

- Remove the port seals **(1)** from the cabinet.

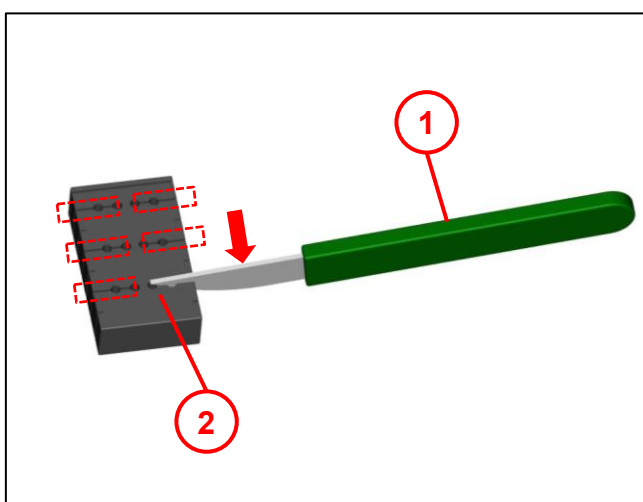

Fig. 14

- Use a cutting tool **(1)** to completely cut through the front and rear side of the port seal as far as the second hole **(2)**.
- 24x optical fibre cable version.

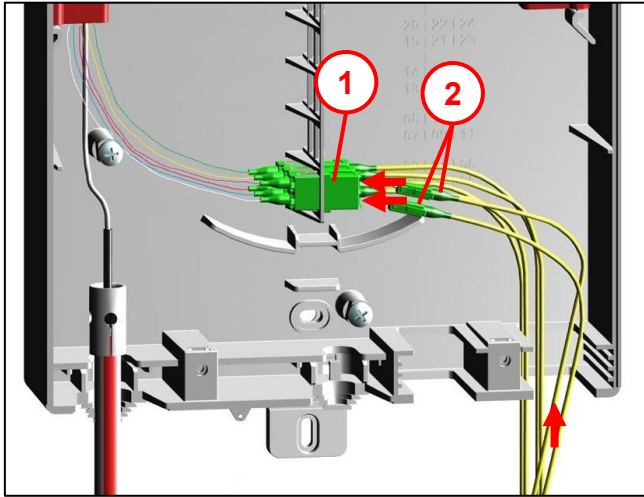

Fig. 15

- Insert the LC-APC patch cable (2) into the cabinet and connect it to the couplers (1).

6.5 Inserting the LC-APC patch cable into the port seal

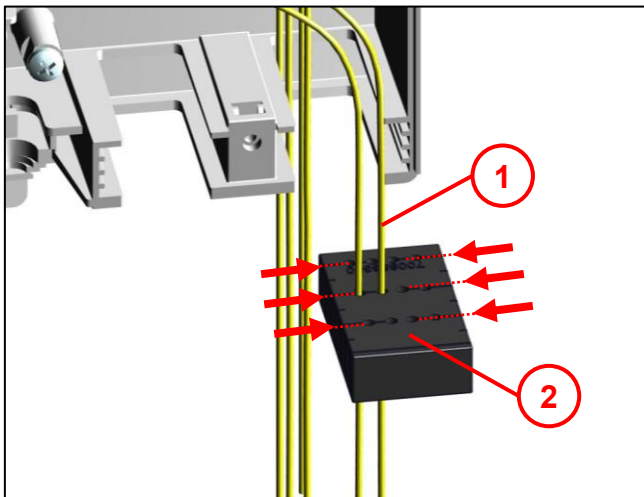

Fig. 16

- Insert the optical fibre cables \varnothing 1.8 – \varnothing 3.4 mm (1) into the sides of the port seal (2).

Note!

Refer to section 6.6 for a layout plan for outgoing optical fibre cables in the port seal!

6.6 Layout plan – Optical fibre cables

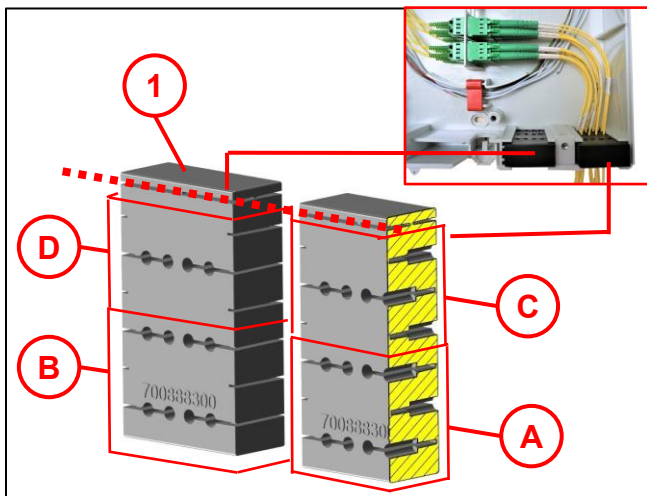

Fig. 17

Block “A”: slots 1 - 12

Block “B”: slots 13 - 24

Block “C”: slots 25 - 36

Block “D”: slots 37 - 48

Note:

Cut off the upper part of the port seal (1) for cables with a diameter of more than 2.8 mm.

6.7 Complete port seal

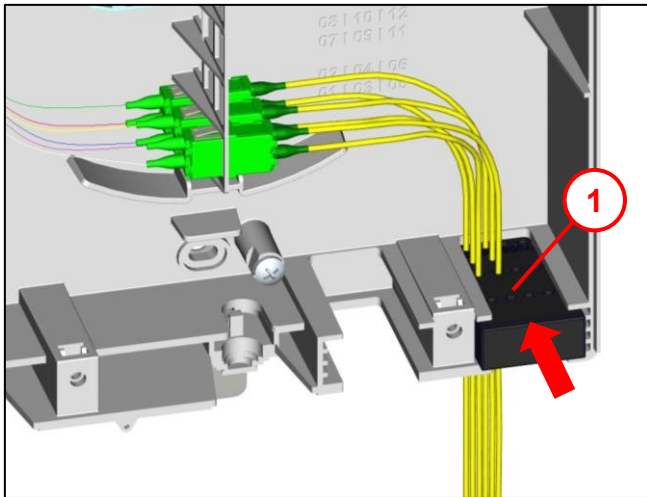

Fig. 18

- Insert the fully assembled port seal **(1)** into the cabinet.

6.8 Closing the cover

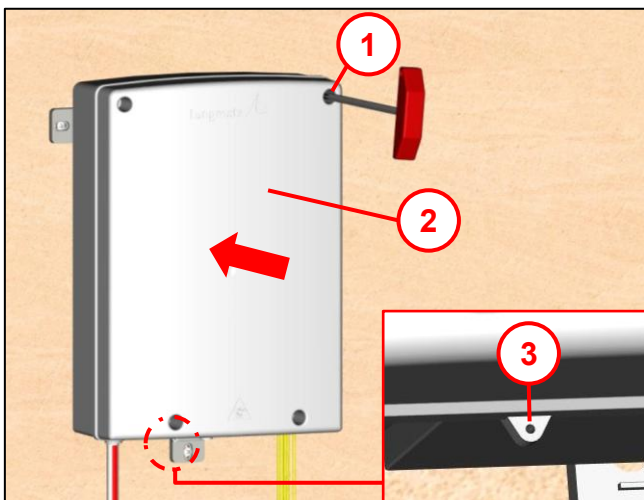

Fig. 19

- Position the cover **(2)** and screw into place using 4x sealing screws M4 (Torx 20) **(1)**.
- There is a possibility of sealing at the tab formed **(3)**.

7 Material defects

Langmatz GmbH accepts liability for material defects in the product as per Section 434 BGB (German Civil Code) for 24 months, starting from the date on the purchase receipt.

Within the scope of liability, all parts that become damaged due to manufacturing faults or material defects will be replaced or repaired free of charge.

The purchaser must report any deficiency complaints immediately in writing.

Claims by the purchaser for damages due to material defects or for whatever legal reason will not be accepted.

Any damage or failure caused by the following are also excluded from liability

- Incorrect use,
- Natural wear and tear
- Intervention by third parties.

We accept no liability for damage caused by force majeure or transport.

Repairs due to a complaint about a defect do not extend the warranty period for the replaced parts or for the product.

8 Quality management

The Langmatz GmbH quality management system is certified to DIN EN ISO 9001.

9 Disclaimer/Warranty

The information in this technical document is presented appropriately and correctly in compliance with the technical regulations, and to the best of our knowledge. However, this does not confer any guarantee of particular characteristics. In this context, the company that operates the products supplied by Langmatz GmbH is expressly obliged to decide, based on its own judgement, whether the products are suitable and appropriate for the application or use being considered. The product liability accepted by Langmatz GmbH relates exclusively to our conditions of sale, delivery, and payment. Langmatz GmbH accepts no liability on the basis of random, indirect and resultant consequential damage, or of any damage attributable to any use of the product other than its intended purpose as described.

10 Contact

Langmatz GmbH
Am Gschwend 10
82467 Garmisch-Partenkirchen, Germany

Phone: +49 88 21 920 – 0

Email: info@langmatz.de
www.langmatz.de

79 100 0195 / 001 | Last updated 18.05.2026