

Installation Instructions for Polycarbonate Manholes



Contents

<u>1</u>	<u>General information</u>	<u>4</u>
<u>2</u>	<u>Safety information</u>	<u>4</u>
<u>3</u>	<u>Product description</u>	<u>5</u>
	<u>3.1 Dimensions</u>	<u>5</u>
	<u>3.2 Technical data – Single frame for wall installation</u>	<u>5</u>
<u>4</u>	<u>Package includes</u>	<u>6</u>
	<u>4.1 Required tools (not included)</u>	<u>7</u>
<u>5</u>	<u>Foundation pit base</u>	<u>7</u>
	<u>5.1 General</u>	<u>7</u>
	<u>5.2 Preparing the foundation pit base</u>	<u>8</u>
<u>6</u>	<u>Manhole installation</u>	<u>9</u>
	<u>6.1 Constructing the base</u>	<u>9</u>
	<u>6.1.1 Installing the complete manhole</u>	<u>9</u>
	<u>6.1.2 Opening the manhole cover</u>	<u>9</u>
	<u>6.1.3 Installing single manhole parts</u>	<u>10</u>
	<u>6.1.4 Connecting the individual parts of the manhole</u>	<u>10</u>
	<u>6.1.5 Installing the steel frame</u>	<u>11</u>
	<u>6.1.6 Optional frame anchor from steel frame to top frame</u>	<u>11</u>
	<u>6.2 Manhole structure for new routes</u>	<u>12</u>
	<u>6.2.1 Removing the predetermined breaking point for Ø110 mm/Ø50 mm cable</u>	<u>12</u>
	<u>6.2.2 Installing the stepped grommets/protective pipe seals</u>	<u>12</u>
	<u>6.2.3 Fitting the micropipe adapter</u>	<u>12</u>
	<u>6.3 Optional manhole structure for existing routes</u>	<u>13</u>
	<u>6.3.1 Installing an overbuild frame for existing Ø50 mm pipes</u>	<u>13</u>
	<u>6.3.2 Inserting existing pipes</u>	<u>13</u>
	<u>6.3.3 Installing an overbuild frame for existing Ø110 mm pipes</u>	<u>13</u>
	<u>6.4 Backfilling the foundation pit up to the lower edge of the top layer</u>	<u>14</u>
	<u>6.5 Inserting the manhole cover</u>	<u>14</u>
	<u>6.6 Constructing the top layer</u>	<u>17</u>
<u>7</u>	<u>Optional: Manhole installation with height adjustment</u>	<u>18</u>
	<u>7.1 When using casting mortar</u>	<u>18</u>
	<u>7.2 When using dry mortar</u>	<u>20</u>
<u>8</u>	<u>2-piece manhole cover</u>	<u>22</u>
	<u>8.1 Opening the manhole cover</u>	<u>22</u>
	<u>8.2 Inserting and closing the manhole cover</u>	<u>22</u>
	<u>8.1 Inserting and removing the 2-piece concrete-lined manhole cover</u>	<u>23</u>
<u>9</u>	<u>Procedure for paving Langmatz manhole covers in accordance</u>	<u>24</u>
	<u>9.1 Galvanised steel manhole cover</u>	<u>24</u>
<u>10</u>	<u>Maintenance</u>	<u>25</u>
<u>11</u>	<u>Material defects</u>	<u>26</u>
<u>12</u>	<u>Quality management</u>	<u>26</u>
<u>13</u>	<u>Disclaimer/Warranty</u>	<u>26</u>

1 General information

These instructions are supplied with the equipment.



Caution!

Any person involved in the installation, operation and repair of the product must first read, understand and follow these instructions. We accept no liability for damage and operating malfunctions caused by failure to comply with these instructions.

In the interest of further development, we reserve the right to change individual assemblies and accessories as considered necessary for further safety and performance improvements, while preserving the main features.

The copyright to these instructions remains with Langmatz GmbH.

2 Safety information

The “polycarbonate manhole” is designed for stationary use underground as a

- cable draw manhole,
- telecommunication distribution point/optical distribution frame,
- energy distribution system,
- system to accommodate electronic components.

When the manhole is used for electronic components, it is not suitable for use in potentially explosive atmospheres.

The product corresponds to the latest state-of-the-art technology at the time of printing and is delivered in an operationally safe condition. Unauthorised modifications, particularly to safety-related parts, are prohibited.

Langmatz GmbH warns against misuse of the product. Work on electrical or electronic fixtures may only be performed by qualified electricians/optical fibre specialists.

The operator is responsible for installing, operating and maintaining the fixtures.

The operating company is responsible for the following:

- Preventing danger to life and limb of users and third parties.
- Ensuring operational safety.
- Precluding downtime and environmental impact due to incorrect handling.
- Ensuring that protective clothing is worn when working with or on the product.



Do not use the product if it is damaged. Please contact the hotline (see chapter 0).



Caution!

Applicable occupational-safety and environmental-protection regulations must be observed during installation, operation and maintenance or repair.

3 Product description

Since Langmatz polycarbonate manholes come in a wide variety of sizes and versions, these instructions are based on one product by way of example: manhole – clear dimension (CD) 400 x 800 mm / 750 mm high.

3.1 Dimensions

(Example product, CD 400 x 800 mm)

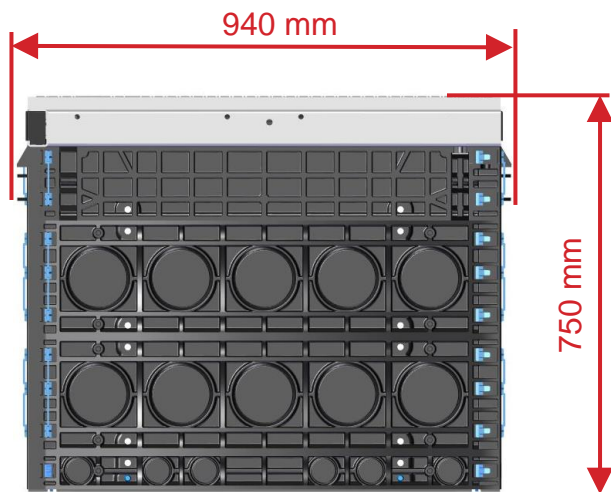

Fig. 1

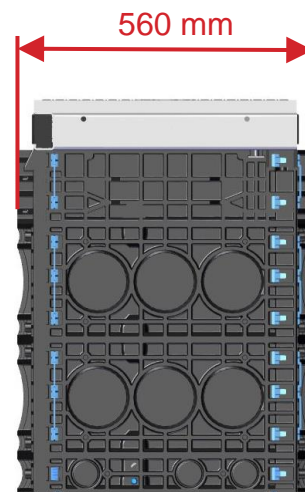

Fig. 2

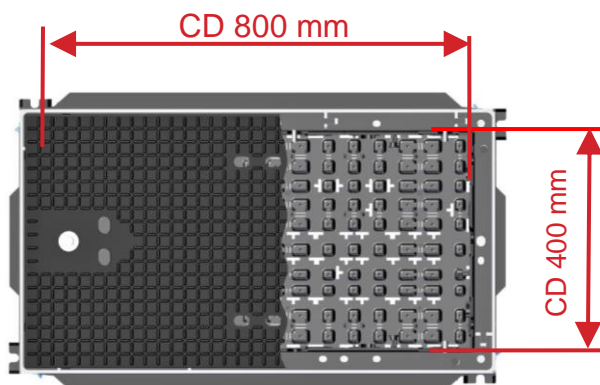

Fig. 3

3.2 Technical data – Single frame for wall installation

Dimensions L x W x H:	940 x 560 x 750 mm
Total weight:	Approx. 135 kg
Frame component/base plate material:	Polycarbonate (PC)/polypropylene (PP)
Steel frame material:	Hot-dip galvanised steel
Manhole cover variants:	Cast steel: Concrete-lined: Paveable: Chequered stud plate:
Manhole closure variants:	Locking mechanism/screw connection

4 Package includes

(Example product, CD 400 x 800 mm/H 750 mm)

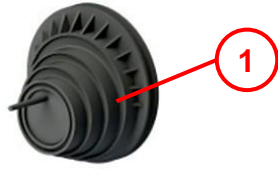

Fig. 4



Fig. 5

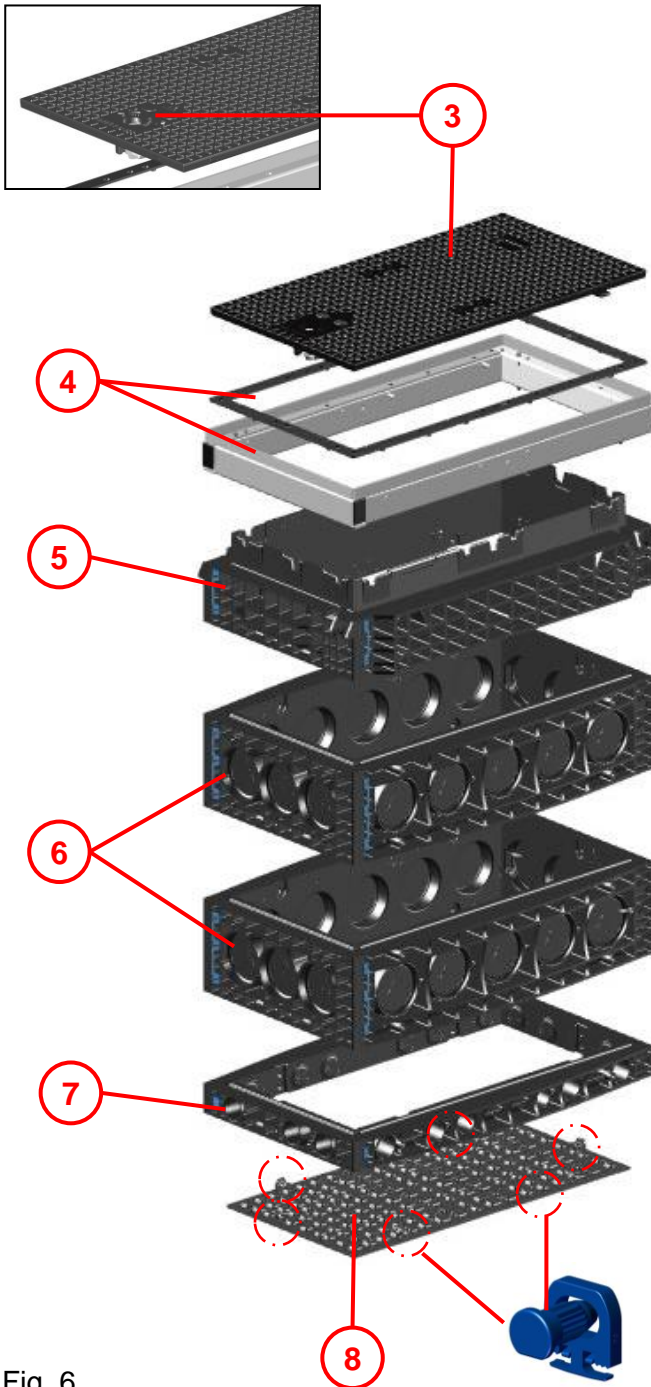

Fig. 6

Complete manhole comprised of:

- | | |
|---------------|--|
| Item 1 | 4x Ø110 mm stepped grommet |
| Item 2 | 18x dual fixing dowel mounting plug (number depends on design) |
| Item 3 | 1x manhole cover
- Cast steel
- With locking mechanism (depending on design) |
| Item 4 | 1x steel frame with damping pad (elastomer) |
| Item 5 | 1x top frame H=140 mm |
| Item 6 | 2x frame component H=220 mm (number depends on design) |
| Item 7 | 1x frame component H=70 mm |
| Item 8 | 1x base plate with mounted dowel clips (number depends on design) |

4.1 Required tools (not included)

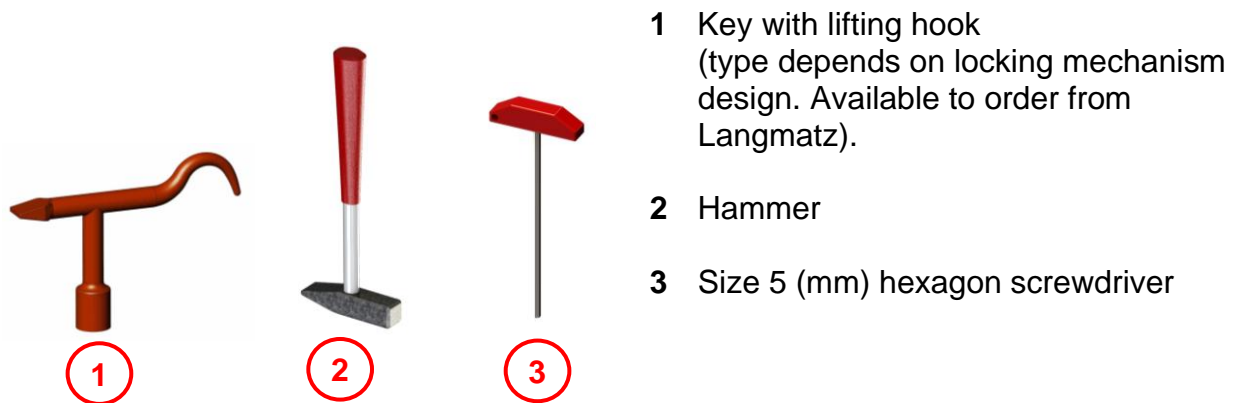

Fig. 7

5 Foundation pit base

5.1 General

The manhole must be installed by a specialist company.

Before preparing a load-bearing foundation pit base, the ground conditions must be assessed.

- For manholes with an overall height less than 680 mm, the highest groundwater level must be at least 1,200 mm below ground level.
- The manhole must be installed in “non-cohesive” to “cohesive” mixed soils.
- Group G1 to G3 soil types as per ATV-DVWK-A (German Association for Water, Wastewater and Waste) 127, and/or soil groups GE, GW, GI, SE, SW, SI, GU, GT, SU, ST, GU*, GT*, SU*,ST*, UL and UM as per DIN 18196.



Caution!

- **Direct installation under the carriageway is not recommended.**
- **Reason:**
 - **More difficult access with moving traffic**
 - **Higher noise development**
- **If the manhole is installed in the roadway, Langmatz recommends the use of “concreted” manhole covers.**

ZTV A-StB 12 (Supplementary Technical Contract Conditions and Guidelines for the Construction of Asphalt Roads) must be observed for the construction of (vehicle) traffic areas!

5.2 Preparing the foundation pit base

When preparing the foundation pit, observe the following documentation from the Gütegemeinschaft Leitungstiefbau e.V. (Underground Cable Line Construction Quality Association):

“Procedural instructions for working in underground cable line construction”.

The position and depth of the foundation pit base must be matched to the installation situation. The upper edge of the manhole cover must lie completely flush with the surrounding ground level, and must not project.

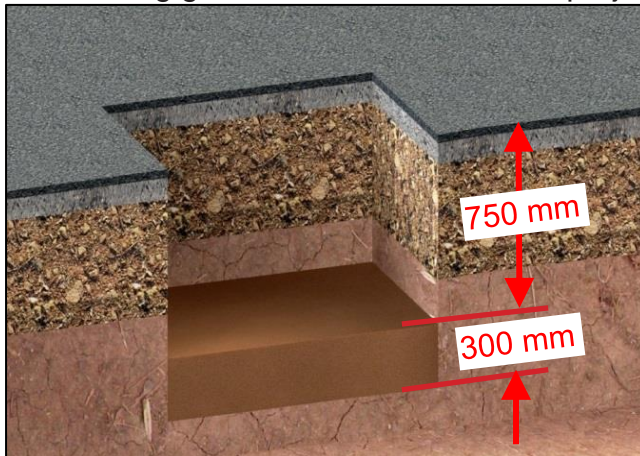

Fig. 8

Situation „A“

For pedestrian areas:

- Use an underfill/bottom layer at least 300 mm thick.
- The underfill/bottom layer must consist of “non-cohesive” to “cohesive” mixed soil (group G1 soil types as per ATV-DVWK-A127).
- The underfill/bottom layer must be layered and compacted to $D_{Pr} \geq 98\%$.

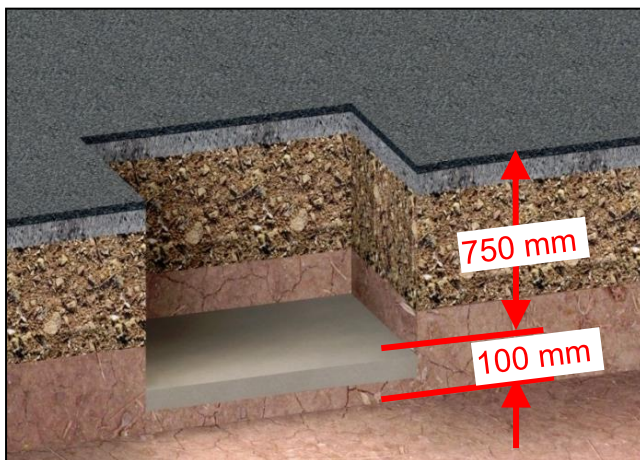

Fig. 9

Situation „B“

For vehicle traffic areas:

- Compact the pit base according to the requirements.
- For group G1/G2 soil types as per ATV-DVWK-A 127 (soil groups GE, GW, GI, SE, SW, SI, GU, GT, SU, ST as per DIN 18196):
- Use a concrete load-bearing layer at least 100 mm thick (tamped concrete, strength class $\geq C8/10$).

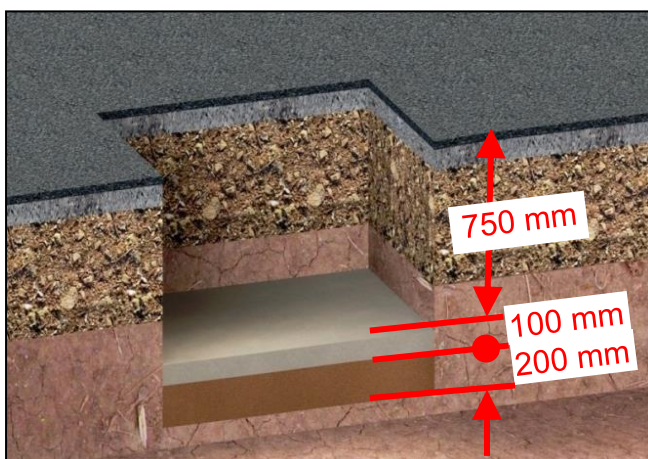

Fig. 10

Situation „C“

For vehicle traffic areas:

- For group G3 soil types as per ATV-DVWK-A 127 (soil groups GU*, GT*, SU*, ST*, UL, UM as per DIN 18196):
- Use an underfill of group G1 soil types according to ATV-DVWK-A 127. Minimum thickness 200 mm. The underfill must be layered and compacted to $D_{Pr} \geq 98\%$.
- Use a concrete load-bearing layer at least 100 mm thick (tamped concrete, strength class $\geq C8/10$).

6 Manhole installation

6.1 Constructing the base

6.1.1 Installing the complete manhole

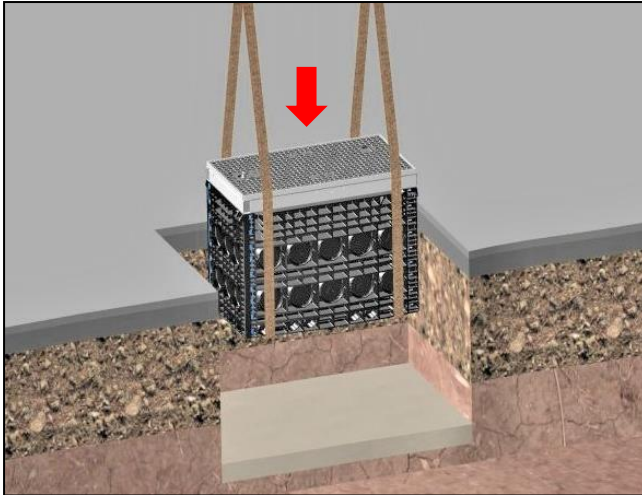

Fig. 11

- Place the complete manhole on the foundation pit base, or construct the manhole body depending on how it is supplied (see Fig. 14 - Fig. 16).



Warning:

- When inserting the manhole, place slings or similar around the entire structure.
- If the manhole tips or drops, it may cause injury.
- Where manholes are factory-fitted with crane lugs, these must be used.

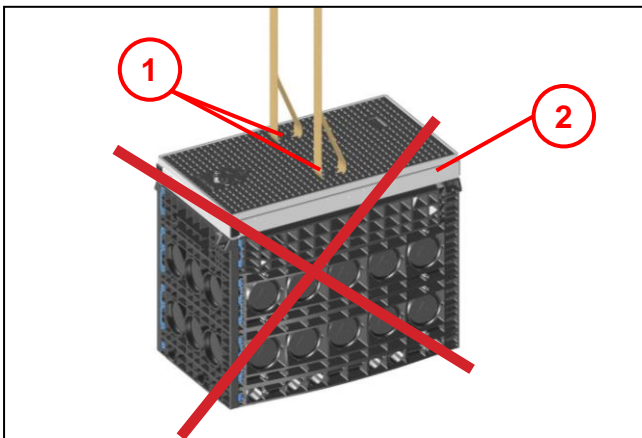

Fig. 12



Warning:

- The existing lifting openings in the manhole cover (1) may not be used to lift the manhole itself.
- The manhole cover (e.g. cast) could rip out, damaging the steel frame (2).

6.1.2 Opening the manhole cover

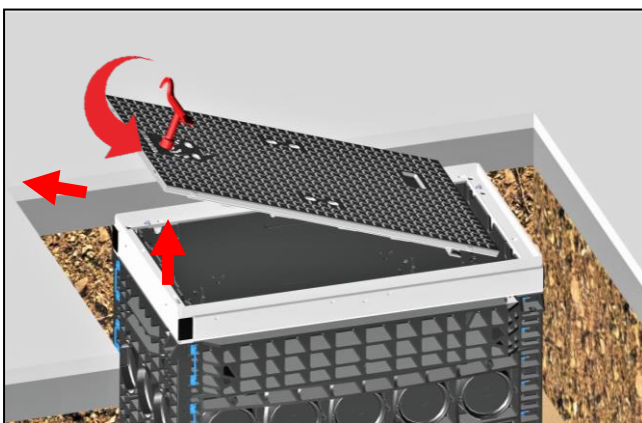

Fig. 13

- To open the manhole cover, turn the lock catch to the "OPEN" position (anticlockwise 90°) using the appropriate key.
- With a suitable tool, lift the manhole cover and pull it out sideways.

6.1.3 Installing single manhole parts

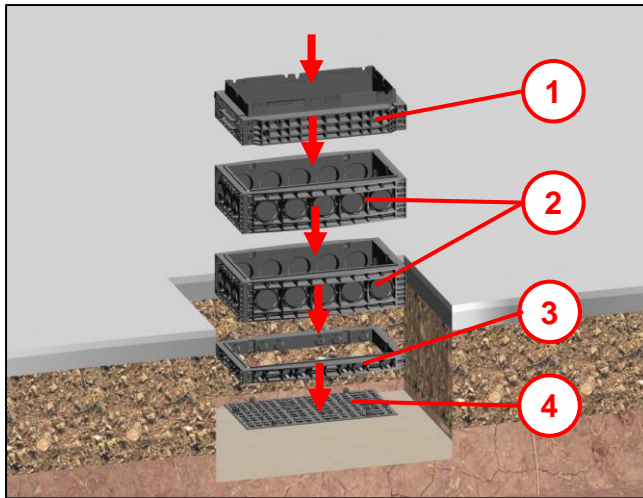

Fig. 14

- Place the base plate **(4)** on the foundation pit base.
- Place the H=70 mm frame component **(3)** on the base plate.
- Place the H=220 mm frame components **(2)** on top of each other (number based on design).
- Finally, place the top frame **(1)** on top of the frame structure.

6.1.4 Connecting the individual parts of the manhole

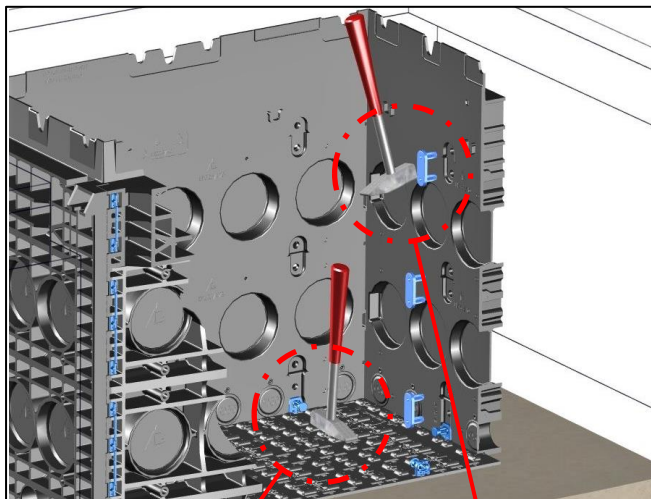
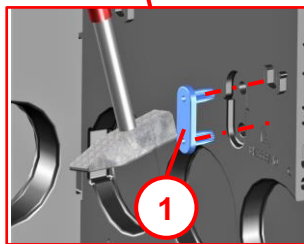
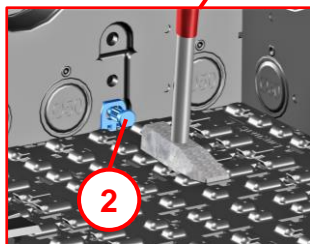

Fig. 15

- To connect the frame components, drive in the supplied dual fixing dowel mounting plugs **(1)** from the inside.
- To connect the base plate to the frame component, use the enclosed dowel clips with moulded fixing dowel mounting plug **(2)**.
- Drive the fixing dowel mounting plug into the hole in the frame component.

When modifying the manhole structure, drive the fixing dowel mounting plugs through from the outside to the inside of the manhole using a suitable tool.



If the fixing dowel mounting plugs show no sign of damage at this point, they can be reused without any functional impairment.

6.1.5 Installing the steel frame

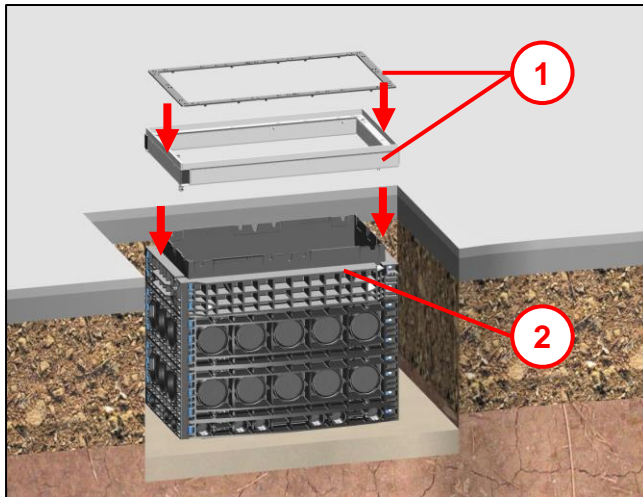

Fig. 16

- Once all the frame components are connected, place the steel frame and (elastomer) damping pad **(1)** on the top frame **(2)**.

6.1.6 Optional frame anchor from steel frame to top frame

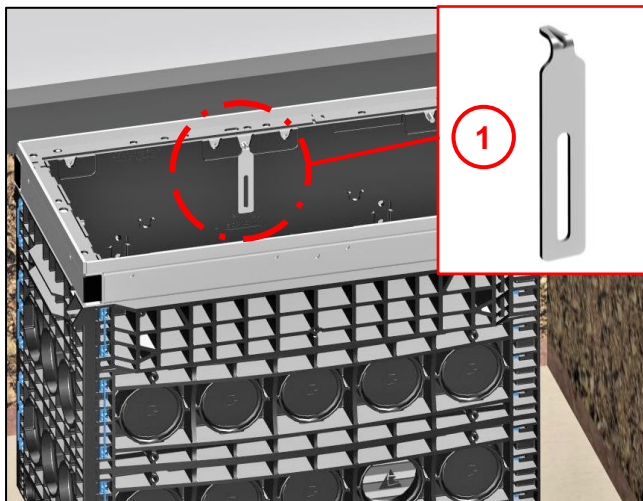

Fig. 17

A frame anchor can optionally be installed to connect the steel frame to the plastic frame. (Not included with standard delivery. Please order separately.)

- Install the frame anchor **(1)** in accordance with the enclosed installation instructions.

6.2 Manhole structure for new routes

6.2.1 Removing the predetermined breaking point for Ø110 mm/Ø50 mm cable ducts

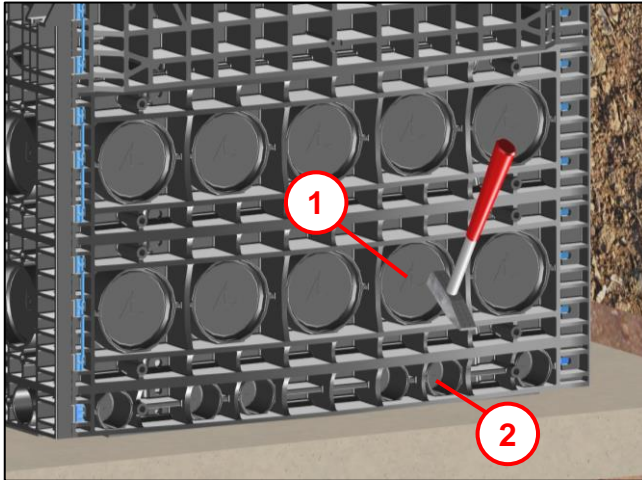

Fig. 18

- Establish the required number of cable ducts and where they need to be.
- Knock out the relevant Ø110 mm **(1)** or Ø50 mm **(2)** predetermined breaking points with a hammer.
- Remove any burrs with a suitable tool.

6.2.2 Installing the stepped grommets/protective pipe seals

(Illustrative example with cables)

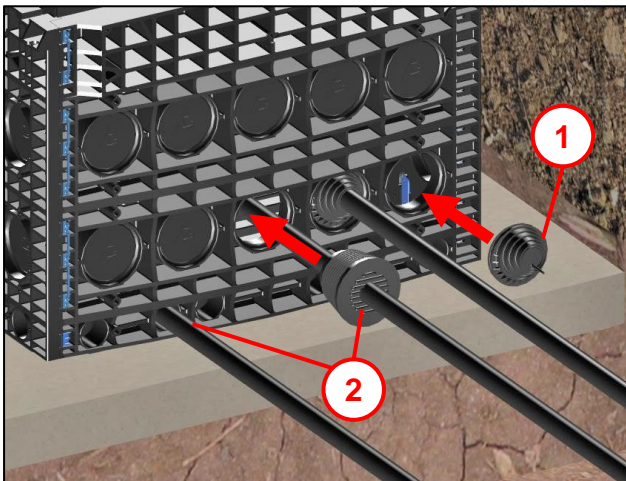



Fig. 19

- Using a suitable tool, open up the required pipe diameter in the predetermined breaking points for the stepped grommet supplied **(1)**.
- Insert the stepped grommet into the opening (Ø110 mm) in the manhole as shown.

To prevent the manhole from silting up, we recommend using a protective pipe seal (Ø110/Ø50 mm) **(2)** when laying grounding cables. (Not included with standard delivery. Please order separately.)

6.2.3 Fitting the micropipe adapter (Illustrative example)

The micropipe adapter **(1)** is not included with standard delivery and must be ordered separately.

- Insert the micropipe adapter **(1)** into the opened cable duct until the surrounding groove around the circumference engages in the opening.
- Guide the micropipe bundle/cables **(4)** (max. Ø 46 mm) into the manhole through the slotted openings **(2)** in the micropipe adapter.
- **Note:** For pipes with max. Ø 50 mm **(3)**, grip the slotted openings **(2)** at the marked tab  and remove.

6.3 Optional manhole structure for existing routes

6.3.1 Installing an overbuild frame for existing Ø50 mm pipes

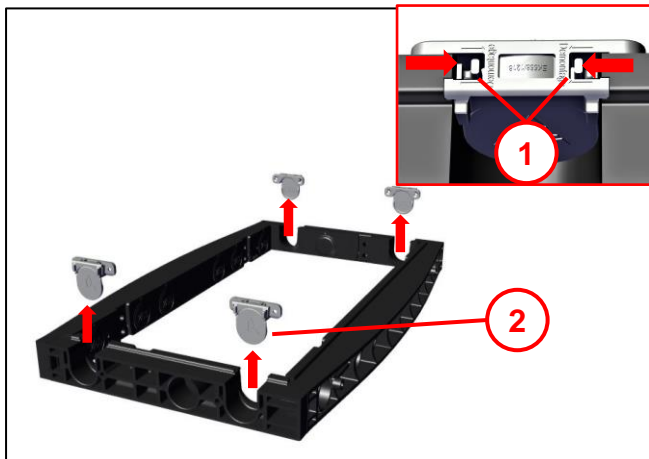

- The pre-mounted adapters (2) are removed by pressing together the two snap lugs (1).

Fig. 20

6.3.2 Inserting existing pipes

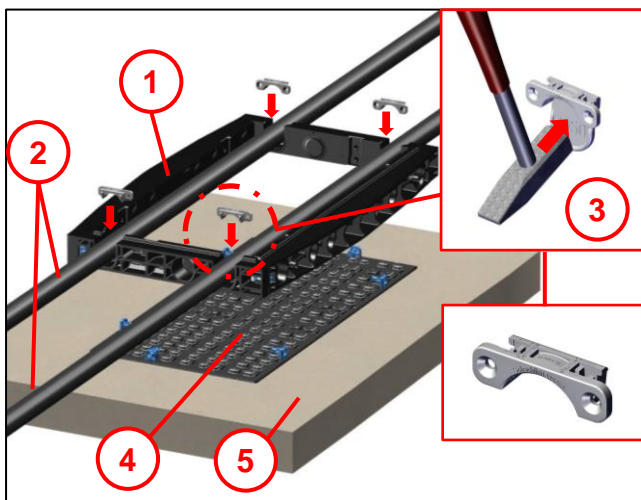

- Place the base plate (4) on the foundation pit base (5).
- Place the overbuild frame (H=70 mm) (1) on the base plate (4) and connect with dowel clips (see chapter Fehler! Verweisquelle konnte nicht gefunden werden.).
- **Note:** If there is no foundation pit base, one must be created (see chapter 5).
- Put the existing Ø50 mm (2) pipes into the recesses.
- Knock out the predetermined breaking point on the adapters (3).
- Place the adapters over the pipes and press them into the recesses until they engage.
- For further assembly of the frame components, see chapters 6.1.3 to 6.1.6.

Fig. 21

6.3.3 Installing an overbuild frame for existing Ø110 mm pipes

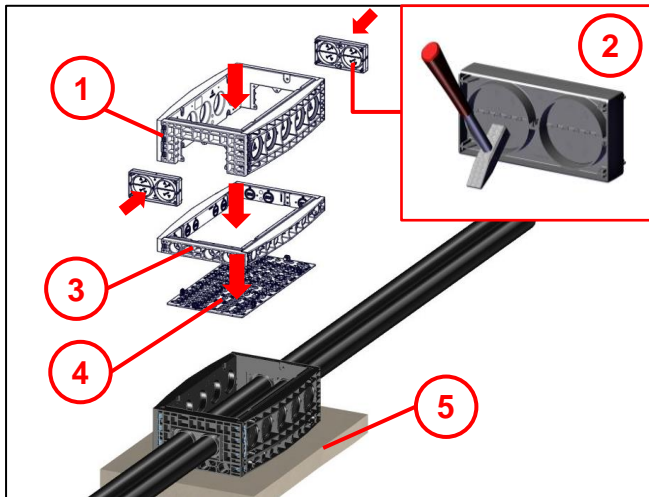

Fig. 22

- Place the base plate (4) on the foundation pit base (5).
- Put the frame component (H=70 mm) (3) on the base plate.
- Place the overbuild frame (H=220 mm) (1) on the frame component (H=70 mm) (3).
- Knock out the predetermined breaking points on the adapter plates (2) and insert them over the existing pipes in the frame.
- **Note:** If there is no foundation pit base, one must be created (see chapter 5).
- For further assembly of the frame components, see chapters 6.1.3 to 6.1.6 siehe Kapitel 6.1.3 bis 6.1.6.

6.4 Backfilling the foundation pit up to the lower edge of the top layer

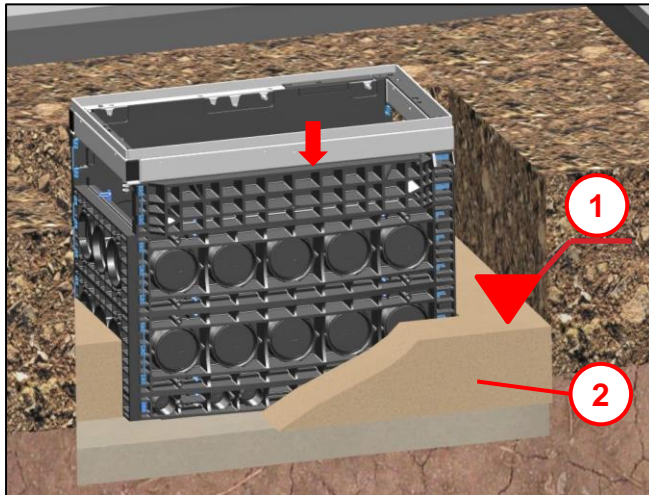

Fig. 23

- Backfill the foundation pit in layers using material suitable for compacting (2) in accordance with ZTV E-StB 09 up to the lower edge of the top layer (1).

6.5 Inserting the manhole cover

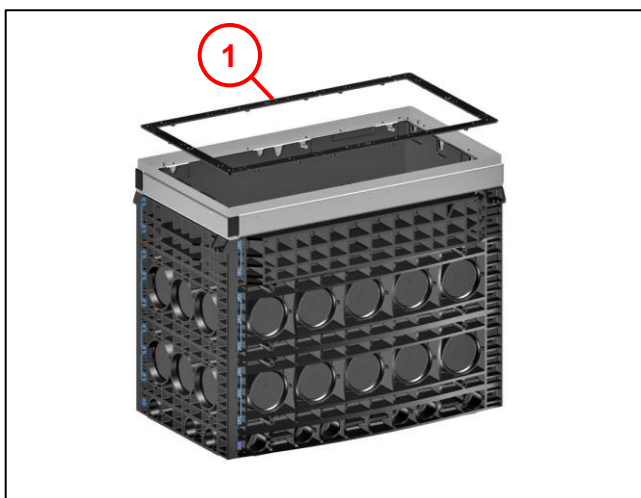

Fig. 24

The following must be observed to ensure proper assembly of any manhole cover:

- The damping pad (1) must be complete.
- The damping pad may not be damaged.
- The damping pad must be cleaned before the manhole cover is inserted to ensure that the manhole cover fits as well as possible.

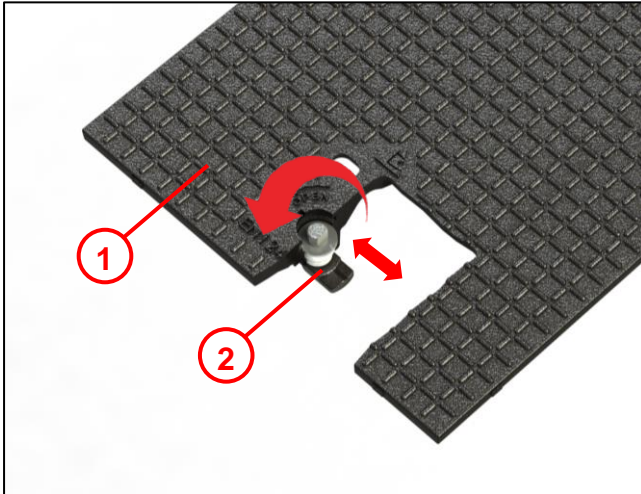

Fig. 25

- Before inserting the manhole cover **(1)**, turn the lock catch **(2)** to the “OPEN” position (anticlockwise 90°).

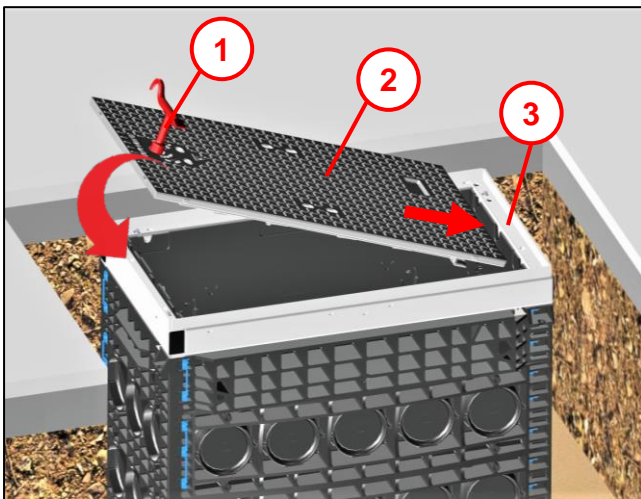

Fig. 26

- Lift the manhole cover **(2)** using a suitable lifting tool **(1)** and place on the steel frame **(3)**.
- Note the next step in Fig. 27 for exactly how to place the cover!

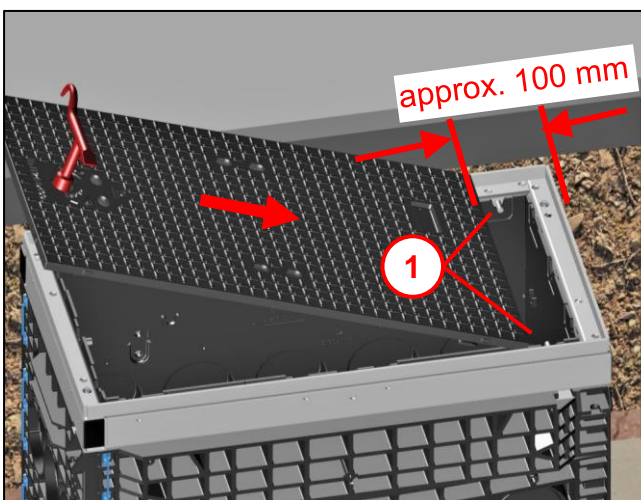
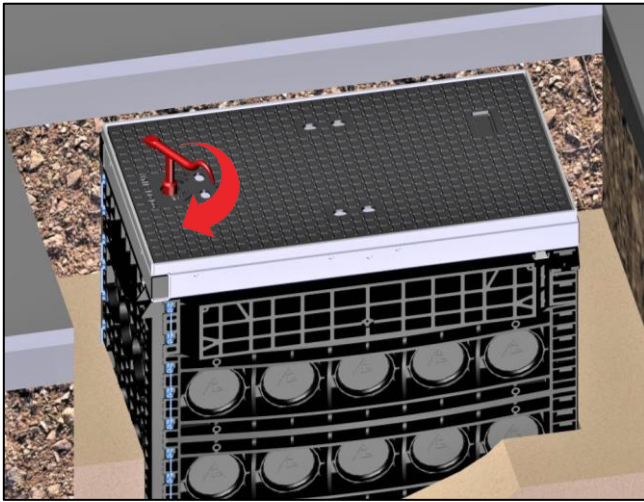

Fig. 27

- Place the manhole cover obliquely approx. 100 mm from the steel frame and slide it until it engages with the retaining bolts on each side **(1)**.



- To lock the manhole cover, turn the lock catch to the “CLOSED” position (clockwise 90°).
- When you hear the retaining bolts click into place, the cover is locked.

Fig. 28

6.6 Constructing the top layer

(Illustrative example)

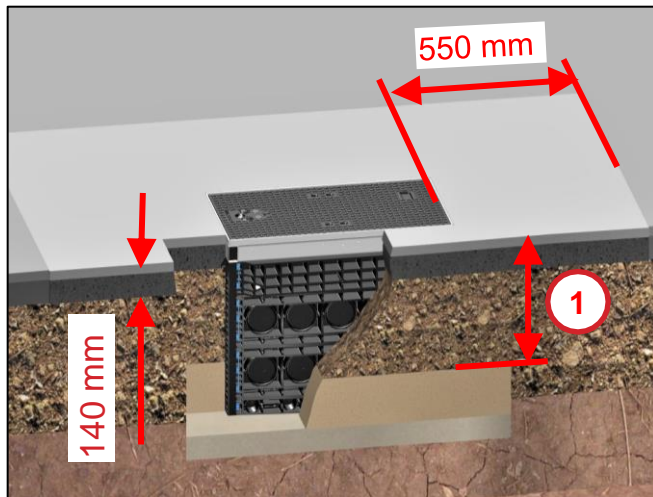

Fig. 29

- Construct the top layer **(1)** as per ZTV A StB 12 (and/or RStO 2012).
- At the surface of the top layer, there must be a strip of concrete or poured asphalt at least 550 mm wide and 140 mm thick (asphalt base layer of at least load class 0.3 according to RStO 2012 (Guidelines for the standardisation of traffic area top layers)).

The manhole assembly without height adjustment is completed.

7 Optional: Manhole installation with height adjustment

7.1 When using casting mortar (similar to AzKm)

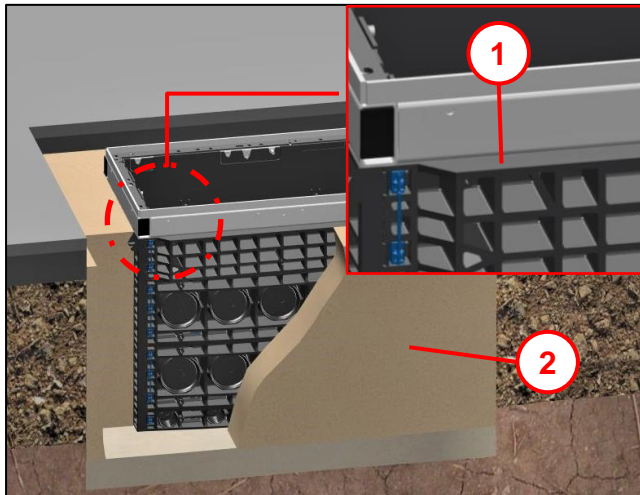

Fig. 30

- Backfill the foundation pit in layers using material suitable for compacting **(2)** in accordance with ZTV A-StB 12 (and/or ZTV E-StB 09) up to the **contact surface of the top frame (1)**.

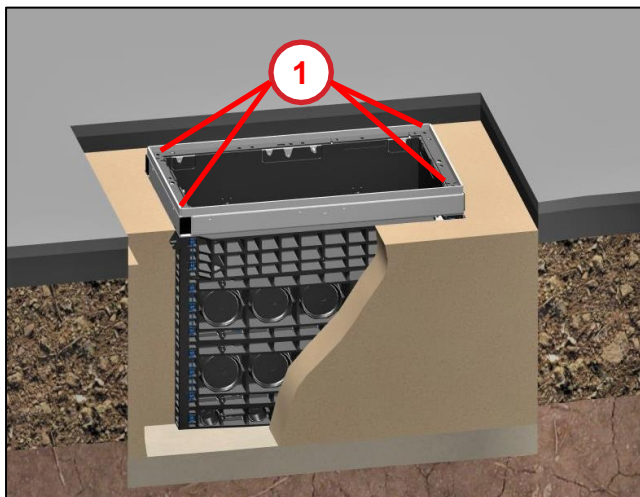

Fig. 31

- The set screws with size 5 (mm) hexagon socket for height adjustment **(1)** are attached to all four corners.

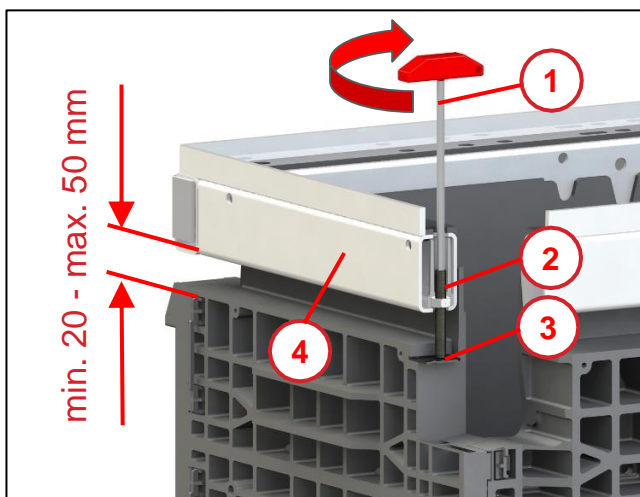

Fig. 32

- Turn the size 5 (mm) hexagon screwdriver **(1)** clockwise at all four height adjustment points to lift the steel frame **(4)** and adjust it to the intended manhole cover height.
- **Note:** The ideal adjustment range is at least 20 mm to maximum 50 mm.
- **Note:** The set screw **(2)** must always be in contact with the support plate **(3)**.

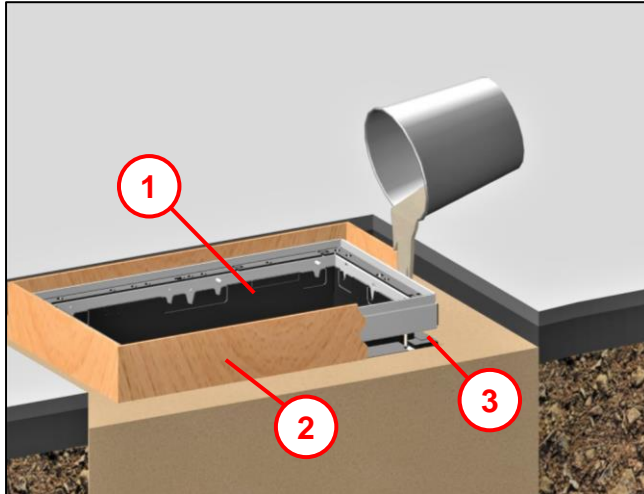

Fig. 33

- To fill in the gap between the top frame and the steel frame (3), a suitable formwork frame should be prepared at the construction site (2) to prevent the casting mortar from flowing away.
- Inside, an existing insulated wall on the top frame (1) prevents casting mortar penetration.
- Backfill according to DIN 18555.
- Compressive strength >35 N/mm² after 28 days.
- Casting mortar: e.g. AzKm
- Supplied e.g. by Ergelit in Alsfeld.

- **Note:**
Do not use foam to fill in the gap! It does not meet load capacity requirements!

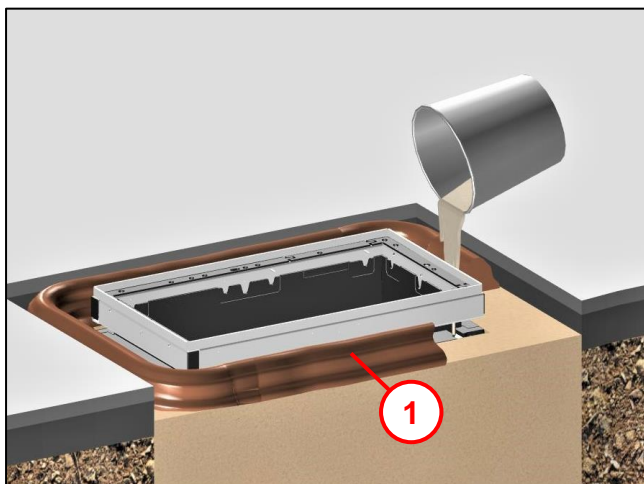

Fig. 34

- Alternatively, a suitable earth wall (1) can be formed to prevent the casting mortar from flowing away.

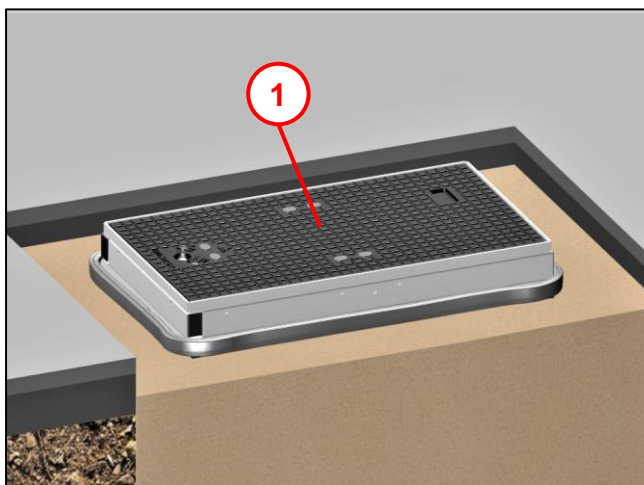

Fig. 35

- Replace and lock the manhole cover (1). (See chapter 6.5).
- **Note:**
The manhole may only be loaded after the casting mortar used reaches the stiffness specified by the manufacturer!
- Build the top layer in accordance with ZTV A-StB 12 (see chapter 6.6).

7.2 When using dry mortar (similar to Kombina 35 S)

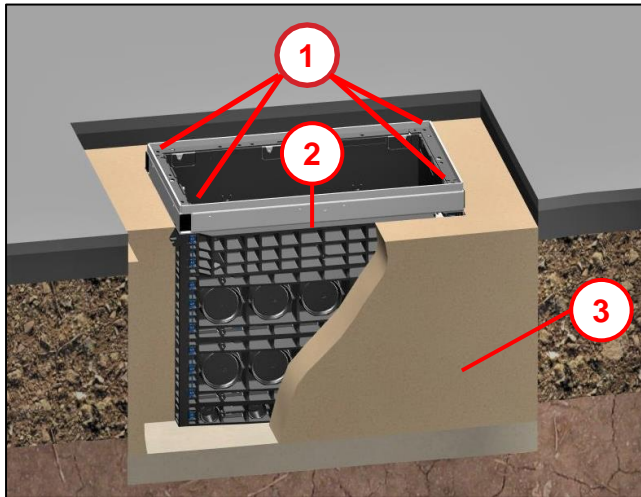

Fig. 36

- Backfill the foundation pit in layers using material suitable for compacting **(3)** in accordance with ZTV A-StB 12 (and/or ZTV E-StB 09) up to the **contact surface of the top frame (2)** (see also Fig. 30).
- The set screws with size 5 (mm) hexagon socket for height adjustment **(1)** are attached to all four corners

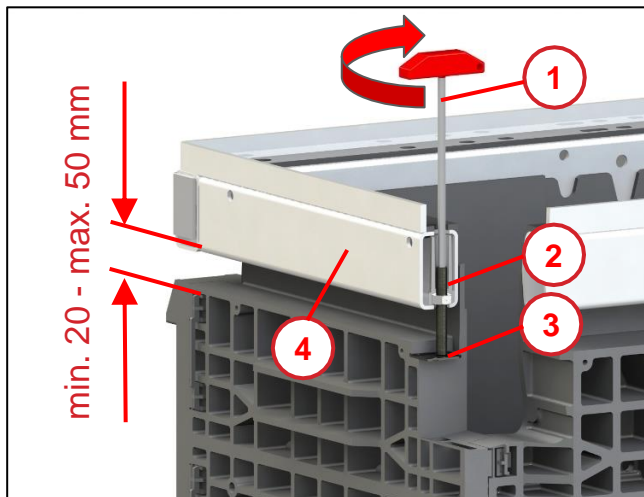

Fig. 37

- Turn the size 5 (mm) hexagon screwdriver **(1)** clockwise at all four height adjustment points to lift the steel frame **(4)** and adjust it to the intended manhole cover height.
- **Note:**
The ideal adjustment range is at least 20 mm to maximum 50 mm.
- **Note:**
The set screw **(2)** must always be in contact with the support plate **(3)**.

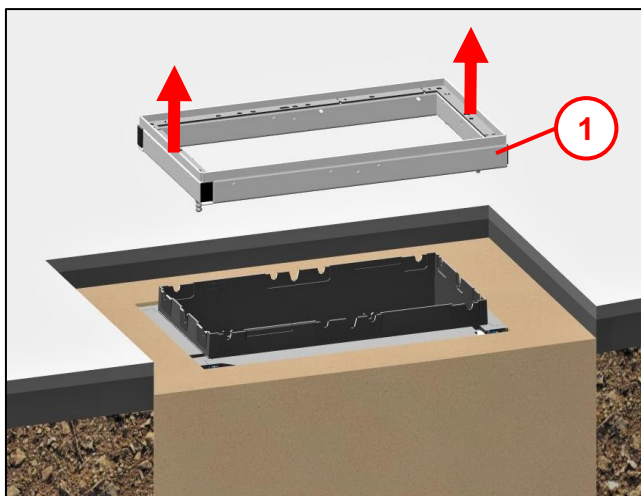

Fig. 38

- Once the height has been adjusted, remove the steel frame **(1)** and set it aside next to the manhole.

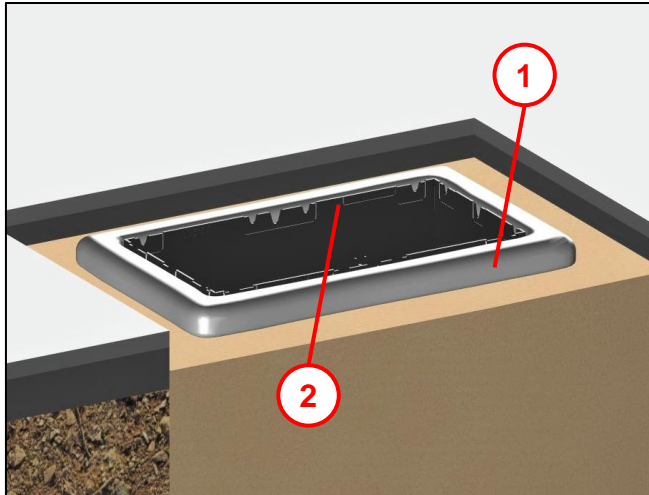

Fig. 39

- To fill in the gap between the top frame and the steel frame, apply dimensionally stable dry mortar (1).
- Inside, an existing insulated wall on the top frame (2) prevents dry mortar penetration.
- Backfill according to DIN 18555.
- Compressive strength >35 N/mm² after 28 days.
- Dry mortar: e.g., Kombina 35 S or similar.
- **Note:** Do not use foam to fill in the gap! It does not meet load capacity requirements!

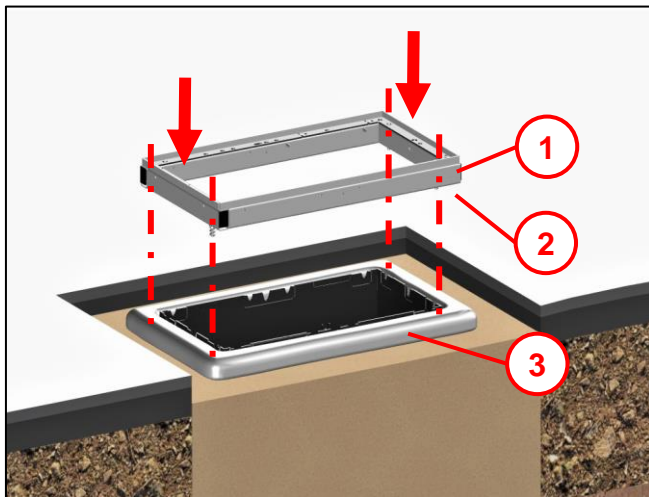

Fig. 40

- Place the steel frame (1) back on the manhole.
- **Note:** Push the set screws (2) from the earlier height adjustment through the dry mortar (3) while it is still soft, until they are back in contact with the support plate (see Fig. 37 - item 3).

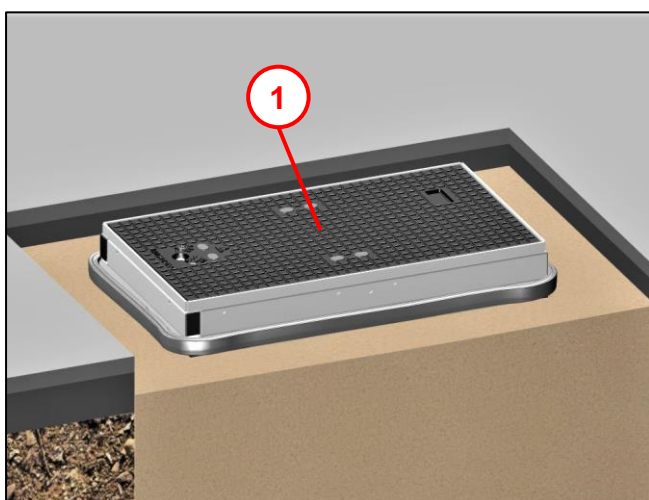

Fig. 41

- Replace and lock the manhole cover (1). (See chapter 6.5).
- **Note:** The manhole may only be loaded after the dry mortar used reaches the stiffness specified by the manufacturer!
- Build the top layer in accordance with ZTV A-StB 12 (see chapter 6.6).

8 2-piece manhole cover

8.1 Opening the manhole cover

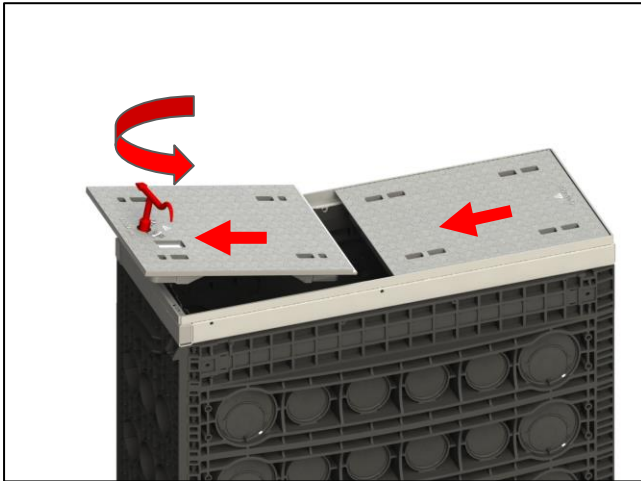

Fig. 42

- To open the manhole cover, turn the lock catch to the “OPEN” position (anticlockwise 90°) using the appropriate key.
- With a suitable tool, lift the manhole cover and pull it out sideways.
- Using a suitable tool, pull the second manhole cover sideways out of the four retaining bolts and lift it up.

8.2 Inserting and closing the manhole cover

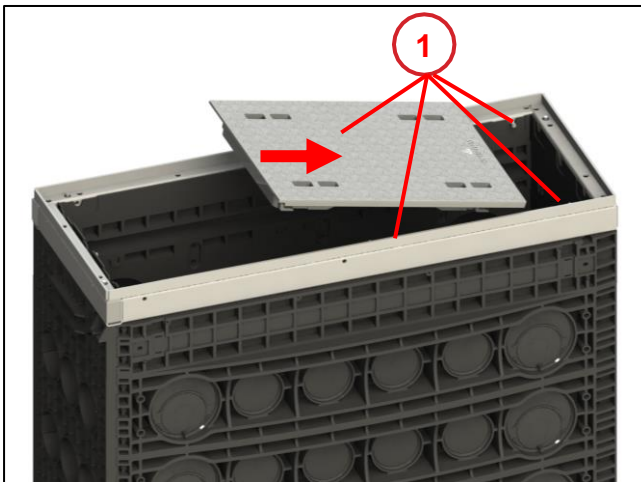

Fig. 43

- To close the manhole cover, first put it in place without the lock catch.
- Set the manhole cover down obliquely and slide it under the retaining bolts **(1)**.

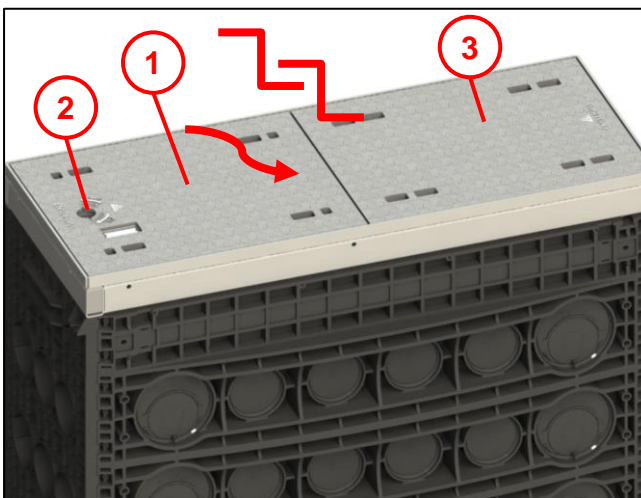

Fig. 44

- **Note:** Before inserting the second manhole cover **(1)**, turn the lock catch **(2)** to the “OPEN” position (anticlockwise 90°).
- Set down the manhole cover with the lock catch **(1)** obliquely and slide it under the manhole cover **(3)** already in place (overlap/underlap).
- The lock catch **(2)** must be on the outside of the manhole.
- Turn the catch to the “CLOSED” position (clockwise 90°). When you hear the retaining bolts click into place, the cover is locked.

8.1 Inserting and removing the 2-piece concrete-lined manhole cover

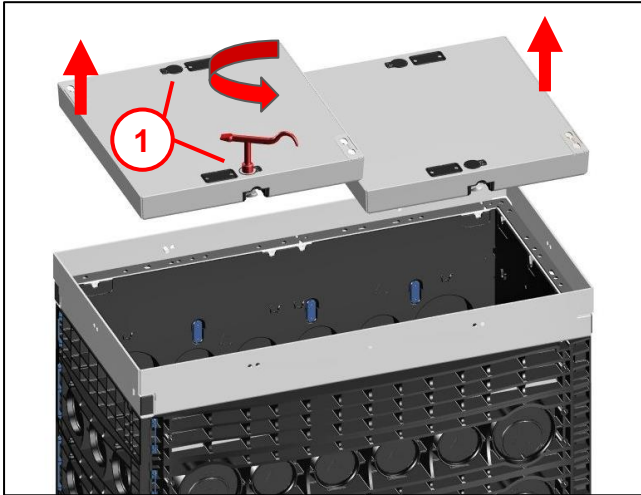

Fig. 45

- Each manhole cover has two lock catches **(1)**.
- To open the manhole cover, turn the lock catches to the “OPEN” position (anticlockwise 90°).
- Lift out the manhole cover using a suitable tool.

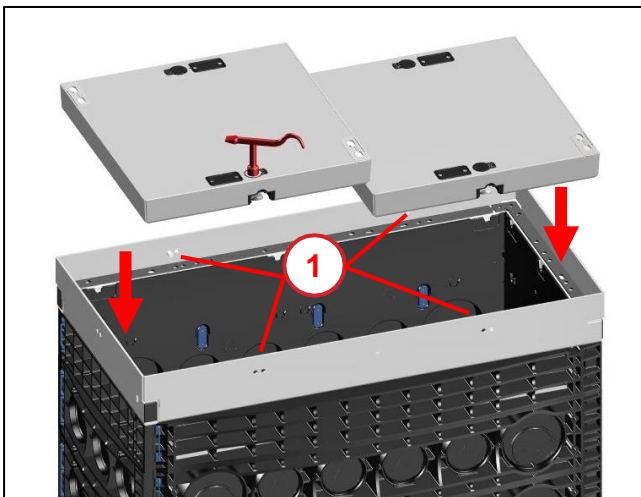

Fig. 46

- To close the cover, turn the lock catches to the “OPEN” position.
- Lift the manhole covers using a suitable tool and place in the steel frame.
- No particular order needs to be followed.
- Turn the lock catches to the “CLOSED” position (clockwise 90°).
- When you hear the retaining bolts **(1)** click into place, the cover is locked.
- **Note:**
See chapter 6.5 Fig. 25

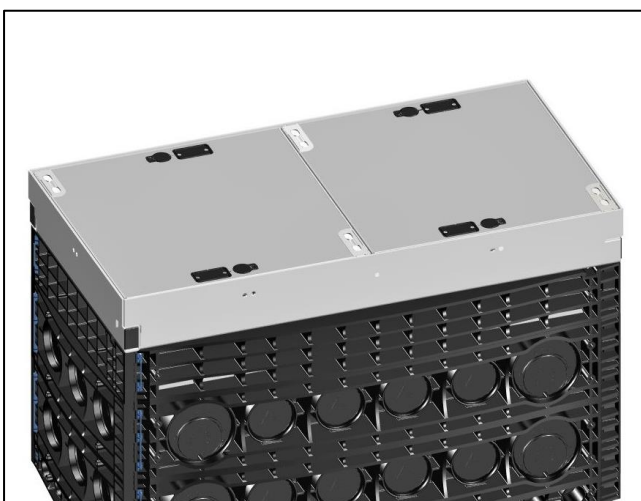

Fig. 47

Installation of the 2-piece concrete-lined manhole cover is now complete.

9 Procedure for paving Langmatz manhole covers in accordance

9.1 Galvanised steel manhole cover

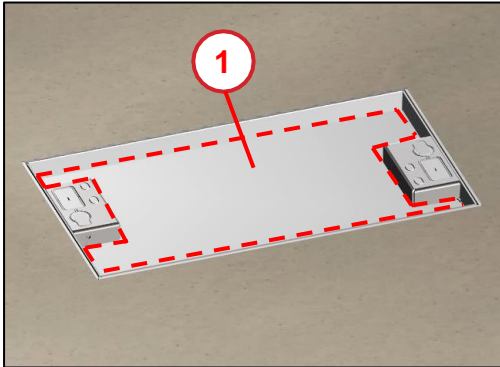

Fig. 48



Fig. 49

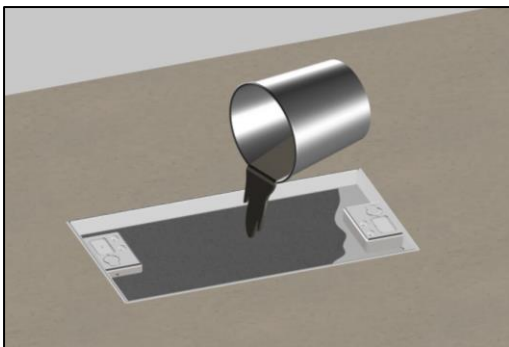

Fig. 50

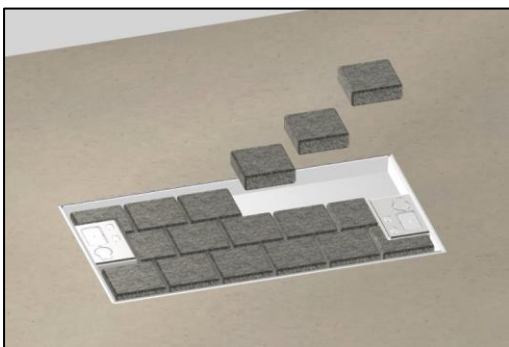

Fig. 51

- Preparation of the concrete filling **(1)** provided ex-works.
- Make sure that the surface of the concrete filling is level, free of dirt or shrinking components.
- For example, if there are potentially shrinking cement-lime layers, then work the surface with a diamond grinding wheel to ensure that it is rough and sufficiently load-bearing.
- First wet the surface with water before laying the paving stones.
- Make sure that the base surface is damp before applying the adhesive mortar.

- Use *PCI Carrament Grey* or similar to professionally bond the concrete slabs or natural stone paving stones.

The thickness of the adhesive layer required can be found in the corresponding data sheet (e.g. for *PCI Carrament Grey* 3-40 mm).

- Tap in the paving stones before the base has fully dried (a stone thickness of 40 mm is recommended).

Note!

Grout after allowing to harden for 6 hours. Use *PCI Pavifix CEM Rapid* or similar to grout the stones.

The surfaces prepared in this way can be fully loaded after approx. 48 hours (at +23 °C and 50% air humidity).

10 Maintenance

Measures	Intervals	Remarks
Before opening, check and clean the manhole surface and locking mechanism.	Before each use.	Only open and close the locking mechanism with the operating key supplied for this purpose.
Check the manhole cover damping pad.	Once a year.	Replace if damaged.
Clean the manhole cover damping pad.	After each use.	Sweeping it off with a broom is sufficient.
For screwed variants:		
<p>Treat the locking screws in the manhole cover with anti-seize paste before screwing them in.</p> <p>Only tighten with a suitable tool (see chapter 4.1). Recommended tightening torque = 46 Nm.</p>	After each use.	Screw in the locking screws by hand only! Anti-seize paste is available from Langmatz (for info, see chapter 0 - Contact).

11 Material defects

Langmatz assumes liability for material defects in the product as per Section 434 BGB (German Civil Code) for 24 months, starting from the date on the purchase receipt.

Within the scope of liability, all parts that become damaged due to manufacturing or material errors will be replaced or repaired free of charge.

The purchaser must report any deficiency complaints immediately in writing.

Claims for damages by the purchaser due to material defects or whatever legal reason will not be accepted.

Any damage or failure caused by the following are also excluded from liability:

- Incorrect use,
- Natural wear and tear,
- Intervention by third parties.

We accept no liability for damage caused by force majeure or transport.

Repairs due to a deficiency complaint do not extend the warranty period for the replaced parts or the product.

12 Quality management

Langmatz GmbH's quality management system is certified to DIN EN ISO 9001.

13 Disclaimer/Warranty

The information in this technical document is presented appropriately and correctly according to technical regulations and to the best of our knowledge. However, this does not confer any guarantee of particular characteristics. The operator of the products supplied by Langmatz GmbH is expressly obliged in this context to decide, based on his/her own judgement, whether the products are suitable and appropriate for the application or use being considered. The product liability accepted by Langmatz GmbH relates exclusively to our conditions of sale, delivery and payment. Langmatz GmbH accepts no liability due to random, indirect and resultant consequential damage, as well as any damage attributable to any use of the product other than for its described and intended purpose.

14 Contact

Langmatz GmbH
Am Gschwend 10
D - 82467 Garmisch – Partenkirchen, Germany

Our hotline: +49 88 21 920 - 137
Telephone: +49 88 21 920 - 0
E-mail: info@langmatz.de
www.langmatz.de

